

KVC UK Ltd
Federal International (2000) Ltd



CAST STEEL VALVES

GATE, GLOBE & CHECK



KVC UK LTD



KVC (UK) LTD SUPPLY RANGE

Gate, globe and check valves are supplied in sizes ranging from 2" thru 48"; pressure ranges 150lb thru 2500lb including Pressure Seal Bonnet design. Materials of construction include carbon steel, stainless steel, duplex, super duplex and exotic alloys.

KVC (UK) Ltd QUALITY SYSTEM

KVC (UK) Ltd quality system is Lloyds approved to BS: EN ISO 9001,2008 and API Q1 9th Edition which ensures that our product is controlled through each stage of manufacture. Valves are supplied with full chemical and mechanical material test certificates to BS EN 10204: 2004 3.1. hydrostatic and pneumatic test certificates are also supplied with each valve.

KVC (UK) Ltd is part of the **Federal International (2000) Ltd Group**. This long standing relationship coupled with our own experience has allowed **KVC (UK) Ltd** to grow and develop into our current and ever improving place within the market.

As part of a large multi-national group, **KVC (UK) Ltd** has the benefit and experience of our united Kingdom based operations together with worldwide access to our parent company resources and our numerous sister companies.

These valuable resources afford us global reach, whilst allowing local access and understanding of both global and local markets, allowing us to provide local technical support in almost any region.

Our key position within the group enables us to offer full management and supply of valves, services and subsidiary equipment. We also offer access to a large and continuously replenished inventory of our core in-house designed products and all others available within the group.

We can supply large quantities of varying product ranges almost instantly or equally manufacture at our various **KVC (UK) Ltd** controlled manufacturing sites with short lead times and impeccable quality.

COMPANY PROFILE

KVC (UK) Ltd specialises in the supply of valves for the Oil, Gas, Chemical, Petrochemical, Pipeline and Water Industries Worldwide. Our valves are used in Offshore, Onshore and Sub-Sea applications.

The Management of the Company has many years experience in the Valve Industry. The organisation and flexibility of the Company allows **KVC (UK) Ltd** to offer short lead-times, even on non-standard valves.

All valves are supplied to the highest quality standards and are fully tested before leaving the factory.

The aim of **KVC (UK) Ltd** is to provide valves and services, which meet or exceed our Customers requirements, at a realistic price and reliable manufacturing time and in so doing remain a market leader supplying a worldwide base of industry leading clients.

REFERENCE STANDARDS AND SPECIFICATIONS

ANSI STANDARDS - AMERICAN NATIONAL STANDARDS INSTITUTE

B1.1	Unified Screw Threads
B1.5	Acme Screw Threads
B1.8	Stub Acme Screw Threads
B1.12	Class 5 Interference - Fit threads
B2.1	Pipe Threads
B16.5	Steel Pipe Flanges, and Flange Fittings
B16.10	Face to Face and End to End Dimensions of Ferrous Valves
B16.11	Forged Steel Fittings, Socket Welding and Threaded
B16.20	Ring-Joint Gaskets and Grooves for Steel Pipe Flanges
B16.21	Non-metallic Gaskets for Pipe Flanges
B16.25	Buttwelding Ends
B16.34	Steel Valves
B18.2.2	Square and Hex Nuts
B31.1	Power Piping
B31.2	Fuel Gas Piping
B31.3	Petroleum Refinery Piping
B31.4	Liquid Petroleum Transportation Piping Systems
B31.5	Refridgeration Piping Systems
B31.6	Chemical Process Piping
B31.7	Nuclear Power Piping
B31.8	Gas Transmission and Distribution Piping Systems
B36.10	Wrought-Steel and Wrought-Iron Pipe

API STANDARDS - AMERICAN PETROLEUM INSTITUTE

6A	Specification for Wellhead Equipment
6D	Specification for Pipeline Valves
597	Steel Venturi Gate Valves
598	Valve Inspection and Testing
600	Steel Gate Valves, Flanged or Buttwelding Ends
603	150-Lb, Light Wall, Corrosion-Resistant Gate Valve for Refinery Use
605	Large Diameter Carbon Steel Flanges

ASTM STANDARDS - AMERICAN SOCIETY FOR TESTING AND MATERIALS

MSS STANDARD PRACTICES - MANUFACTURERS STANDARDISATION SOCIETY OF THE VALVE AND FITTINGS INDUSTRY

SP-6	Finishes- for contact Faces of Connection End Flanges of Ferrous Valves and Fittings
SP-9	MSS Spot Facing Standard
SP-25	MSS Standard Marking System for Valves, Fittings, Flanges and Unions
SP-42	MSS 150Lb Corrosion Resistant Cast Flanged Valves
SP-44	MSS Steel Pipe Line Flanges
SP-45	MSS Bypass and Drain Connection Standard
SP-53	Quality Standard for Steel Castings, Dry Particle Magnetic Inspection Method
SP-54	Quality Standard for Steel Castings, Radiographic Inspection Method
SP-55	Quality Standard for Steel Castings, Visual Method
SP-61	Hydrostatic Testing of Steel Valves

PERFORMANCE FOR ANY APPLICATION

In fluid process systems, it is valves which are the controlling elements. They are responsible for stopping and starting flow, throttling or regulating flow, prevention of backflow and for regulating pressure.

KVC (UK) Ltd valves are used in a wide variety of applications the following descriptions will provide a simple guide in the selection of these types of valves.

GATE VALVES

Gate Valves serve as efficient stop valves with flow in both directions. They are used where a minimum pressure drop is important. Gate valves should not be used for Throttling since partially open gate valves display flow characteristics which will not help maintain accurate and consistent flow control. Partially open gate valves may also be damaged by the high velocity across the valve seats. They function best as ON/OFF valves either in the fully open or fully closed position.

GLOBE VALVES

Globe valves are suited for service where Throttling is required. Globe valve flow characteristics allow accurate and repeatable flow control. Caution should be taken to avoid very close throttling when the pressure drop exceeds around 20%. This close throttling can lead to excessive noise or vibration and can result in damage to the valves and other piping system components. If these conditions are expected please contact KVC (UK) Ltd for advice.

SWING CHECK VALVES

Swing Check Valves prevent backflow through pipelines. The valves can be installed in horizontal or vertical, upward flow, piping. They can serve to offer resistance to flow and are best suited to low velocity service conditions.

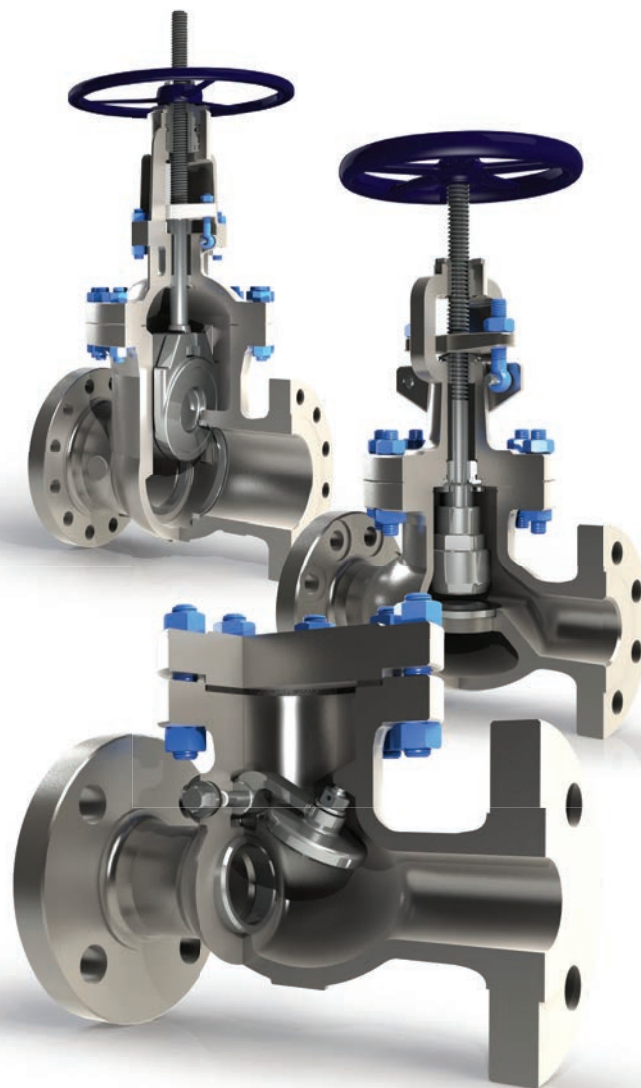

MATERIALS OF CONSTRUCTION (SERVICE CONDITIONS)

ASTM Classification	Service conditions
A216 WCB	For use in service up to 1000°F (537°C) assuming corrosion and oxidation are not a factor (1)(2)(3)
A217 C5	For use in service up to 1200°F (649°C). Offers good corrosion and oxidation resistance.
A351 LCC	For service between -50°F (-46°C) and 650°F (343°C). This material must be quenched and tempered to obtain tensile and impact properties needed at low temperatures.
A351 LC3	For service between -150°F (-101°C) and 650°F (343°C). Subsequent heat treatment is used to obtain tensile and impact properties needed at subzero temperatures.
A351 CF8M	For service up to 1000°F (537°C), where corrosion and oxidation resistance are required.
A351 CF8	For service up to 1000°F (537°C), where corrosion and oxidation resistance are desired, but lower costs than CF8M and slightly lower strength and corrosion resistance can be accepted.

- (1) Upon prolonged exposure to temperatures above 800°F (426°C), the carbide phase of carbon steel may be converted to graphite. Permissible, but not recommended for prolonged use above 800°F (426°C)
- (2) Product used within the jurisdiction of Section 1 Power boilers of the ASME boiler and pressure vessel code is subject to the same temperature limitations as specified in that document
- (3) Product used within the jurisdiction of Power piping, ASME Code for Pressure piping B31.3, is subject to the same maximum temperature limitations placed upon the material in that document.



GATE VALVES

Gate Valves are the most commonly used shut-off valve in the industry today.

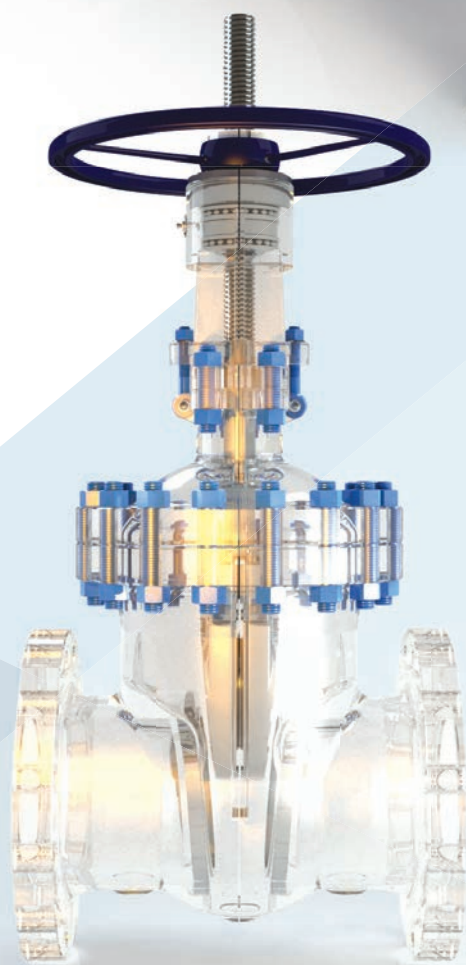

CAST STEEL GATE VALVES

KVC (UK) LTD Gate valves are manufactured to API Std.600 and tested to API Std.598

Gate Valves are the most commonly used shut-off valve in the industry today. They are used where minimum pressure drop and bi-directional on-off service is required. Gate valves are not designed for throttling service. Prolonged use in the partially open position may lead to premature wear and damage to the seating surfaces.

Our standard offering has a rising stem with an outside screw and yoke.

BODY AND BONNET

- Back-Seat Bushing
- Gland can be Re-packed in-situ
- Wedge Clear of Flow in Full Open Position
- Low Pressure Drop across valve

BODY-BONNET JOINT / GASKET

- Range of materials to suit Pressure Classes

WEDGE

- Flexible wedge as standard
- (Solid Wedge available on request)
- Reduces the likelihood of the wedge sticking
- Fully guided wedges



NON FLEXIBLE



FLEXIBLE

WELDED-IN SEAT RING

- Seat Ring is seal welded to eliminate potential leak paths.
- (Renewable seat rings can be supplied on request.)

STEM

- One piece stem, forged tee-head connection
- Rolled or cut ACME threads subject to valve size
- Polished on the packing contact area
- Ensures long life & optimal tightness
- Engineered stem break-point above packing area
- Ensures sealing integrity to atmosphere.

GLAND

- The Gland Flange & Packing Gland are manufactured in two separate pieces
- Adjustable gland in service
- Optional live loaded gland can be specified
- Backseated design allowing the gland packing to be replaced in situ.

STUFFING BOX

- Packing contains corrosion inhibitor to avoid stem pitting.
- Deep stuffing box design ensures long packing life.



END CONNECTIONS

- As Standard production covers valves with:

Flanged ends to ANSI B16.5

- RF** Raised face serrated finish or,
- On request, with any other type of finish

RTJ Ring Type Joint

Others

Butt-welding ends (BW) to ANSI B16.25

- Customer must specify the type of schedule required, or class of pipe, or diameter and bore.

Special end connections on request.

FACE to FACE

- Face to Face dimensions to ANSI B16.10.

HANDWHEEL

- Handwheels designed for ease of operation.

GEAR OPERATED VALVES

- Valves can be supplied with bevel gear operators

MOTOR OPERATED VALVES

- On request valves can be supplied equipped with, or prepared for actuators
- Electric /
- Pneumatic /
- Hydraulic (according to customers' requirements).

- Customer is to advise all service requirements and applicable specification with enquiry.

ACCESSORIES

- OnRequest:
- By-passes, locking devices, chain wheels, floor stands, special extension stems and others.

TESTING

- Standard Testing is in accordance with API 598.
- Customer specific testing by agreement.

CAST STEEL GATE VALVES - ANSI 150

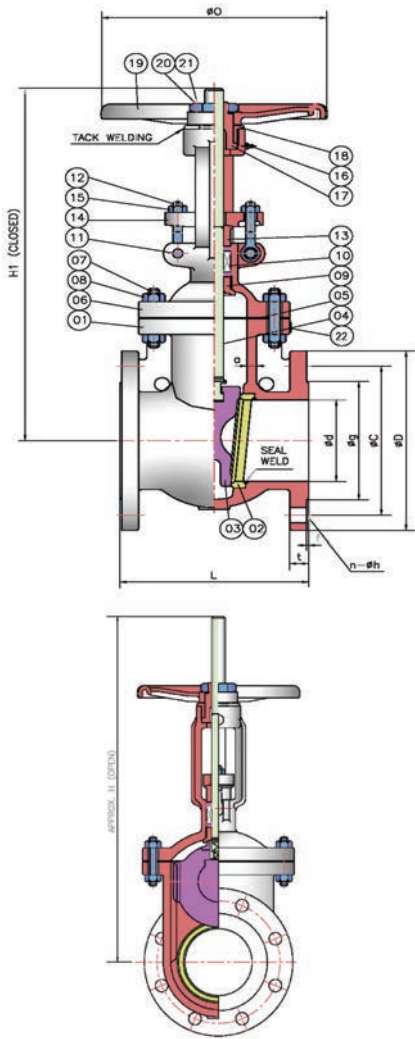

Parts And Material List			FIG . 0112F
No.	Part Name	Material	ASTM Specification
01	Body	Carbon Steel	ASTM A216 WCB
02	Body Seat Ring	Carbon Steel	ASTM A105 ST'L No. 6 Face
03	Wedge	Carbon Steel	ASTM A216 WCB 13Cr Face
04	Stem	Stainless Steel	ASTM A182 F6a
05	Gasket	Stainless Steel + Graphite	ASTM A182 316 + Graphite
06	Bonnet	Carbon Steel	ASTM A216 WCB
07	Bonnet Bolt	Carbon Steel	ASTM A193 B7
08	Bonnet Nut	Carbon Steel	ASTM A194 2H
09	Back Seat Ring	Stainless Steel	ASTM A276 410
10	Packing ring	Graphite	Die Formed / Braided Graphite
11	Hinge Pin	Carbon Steel	-
12	Gland Bolt	Carbon Steel	ASTM A193 B7
13	Packing Gland	Stainless Steel	ASTM A276 410
14	Gland Flange	Carbon Steel	ASTM A216 WCB
15	Gland Nut	Carbon Steel	ASTM A194 2H
16	Grease Nipple	Stainless Steel	2 1/2" and above
17	Yoke Sleeve	Ductile Iron	ASTM A439 D2
18	Yoke Cap	Carbon Steel	-
19	Handwheel	Ductile Iron	-
20	Handwheel Nut	Carbon Steel	-
21	Set Screw	Steel	-
22	Nameplate	Stainless Steel	ASTM A182 F316

OPERATOR OPTIONS

- Gear Operated recommended for size 16" above
- For Gear Dimensional detail contact KVC (UK) Ltd Engineering

SPECIFICATION

- Bolted Bonnet
 - Outside Screw and Yoke
 - Flexible Wedge
 - Oval Bonnet with integral Yoke
 - Rising Stem - Non-rising Handwheel
 - Welded-In / Threaded Seat Rings
 - Raised Face Flanged Ends or Butt Weld Ends
- Other End connections are available on request.

APPLICABLE STANDARDS

Design : API 600
 End Flange : ANSI B16.5
 Weld Ends : ANSI B16.25
 Face-to-Face : ANSI B16.10
 Shell and Seat Test : API 598

MATERIAL

Option available for materials to meet NACE MR0175 requirement.

Dimensional Data (mm)*												
Size	Face-to-Face L	Dia. of Bore d	O.D. of Flange D	ø of Bolt Circle C	O.D. of RF g	Thk of Flange t	Ht. of RF f	ø of Bolt Holes n-h	ø of Handwheel O	Height H/H1	Wall Thk a min	Wt (Kg)
2"	178.0	50.8	150.0	120.7	92.1	16.3	2.0	4-19.1	200	397/322	8.6	18.0
2-1/2"	190.5	63.5	177.8	139.7	104.6	17.9	2.0	4-19.1	200	450/351	9.7	28.0
3"	203.0	76.2	190.0	152.4	127.0	19.5	2.0	4-19.1	250	506/412	10.4	34.0
4"	229.0	101.6	230.0	190.5	157.2	24.3	2.0	8-19.1	250	594/475	11.2	52.0
6"	267.0	152.4	280.0	241.3	215.9	25.9	2.0	8-22.4	350	778/602	11.9	88.0
8"	292.0	203.2	345.0	298.5	269.9	29.0	2.0	8-22.4	350	973/745	12.7	144.0
10"	330.0	254.0	405.0	362.0	323.8	30.6	2.0	12-25.4	400	1160/868	14.2	197.0
12"	356.0	304.8	485.0	431.8	381.0	32.2	2.0	12-25.4	450	1384/1017	16.0	298.0
14"	381.0	336.6	535.0	476.3	412.8	35.4	2.0	12-28.6	460	1560/1128	16.8	406.0
16"	406.0	387.4	595.0	539.8	469.9	37.0	2.0	16-28.6	460	1775/1293	17.5	524.0
18"	432.0	438.2	635.0	577.9	533.4	40.1	2.0	16-32.0	460	1959/1426	18.3	720.0
20"	457.0	489.0	700.0	635.0	584.2	42.3	2.0	20-32.0	540	2155/1555	19.1	1117.0
24"	508.0	590.6	815.0	749.3	692.2	48.1	2.0	20-35.0	540	2535/1835	20.6	1466.0

*Please note dimensions are for information only. Order specific arrangement drawing dimensions will be final.

CAST STEEL GATE VALVES - ANSI 300

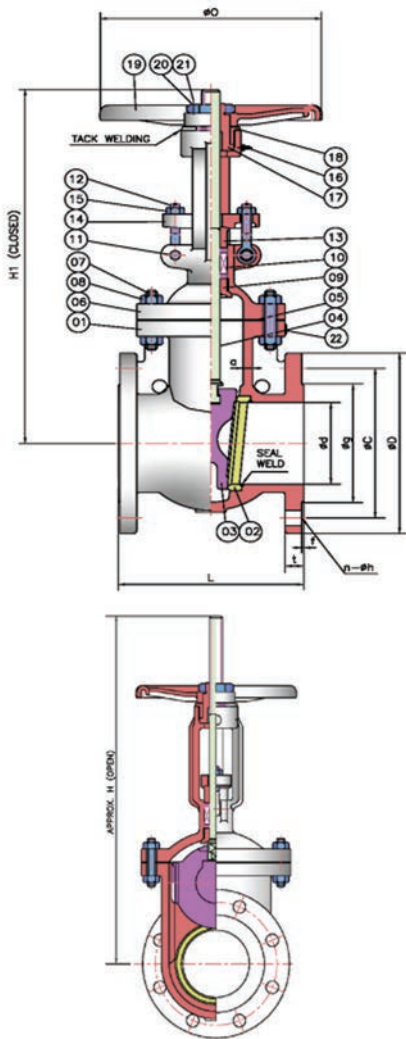

Parts And Material List			FIG . 0312F
No.	Part Name	Material	ASTM Specification
01	Body	Carbon Steel	ASTM A216 WCB
02	Body Seat Ring	Carbon Steel	ASTM A105 ST'L No. 6 Face
03	Wedge	Carbon Steel	ASTM A216 WCB 13Cr Face
04	Stem	Stainless Steel	ASTM A182 F6a
05	Gasket	Stainless Steel + Graphite	ASTM A182 316 + Graphite
06	Bonnet	Carbon Steel	ASTM A216 WCB
07	Bonnet Bolt	Carbon Steel	ASTM A193 B7
08	Bonnet Nut	Carbon Steel	ASTM A194 2H
09	Back Seat Ring	Stainless Steel	ASTM A276 410
10	Packing ring	Graphite	Die Formed / Braided Graphite
11	Hinge Pin	Carbon Steel	-
12	Gland Bolt	Carbon Steel	ASTM A193 B7
13	Packing Gland	Stainless Steel	ASTM A276 410
14	Gland Flange	Carbon Steel	ASTM A216 WCB
15	Gland Nut	Carbon Steel	ASTM A194 2H
16	Grease Nipple	Stainless Steel	2 1/2" and above
17	Yoke Sleeve	Ductile Iron	ASTM A439 D2
18	Yoke Cap	Carbon Steel	-
19	Handwheel	Ductile Iron	-
20	Handwheel Nut	Carbon Steel	-
21	Set Screw	Steel	-
22	Nameplate	Stainless Steel	ASTM A182 F316

OPERATOR OPTIONS

- Gear Operated recommended for size 14" above
- For Gear Dimensional detail contact KVC (UK) Ltd Engineering

SPECIFICATION

- Bolted Bonnet
- Outside Screw and Yoke
- Flexible Wedge
- Oval Bonnet with integral Yoke
- Rising Stem - Non-rising Handwheel
- Welded-In / Threaded Seat Rings
- Raised Face Flanged Ends or Butt Weld Ends

Other End connections are available on request.

APPLICABLE STANDARDS

Design : API 600
 End Flange : ANSI B16.5
 Weld Ends : ANSI B16.25
 Face-to-Face : ANSI B16.10
 Shell and Seat Test : API 598

MATERIAL

Option available for materials to meet NACE MR0175 requirement.

Dimensional Data (mm)*												
Size	Face -to-Face L	Dia. of Bore d	O.D. of Flange D	o of Bolt Circle C	O.D. of RF g	Thk of Flange t	Ht. of RF f	o of Bolt Holes n-h	o of Handwheel O	Height H/H1	Wall Thk a min	Wt (Kg)
2"	216.0	50.8	165.0	127.0	92.1	22.7	2.0	8-19.1	200	422/360	9.7	24.0
2-1/2"	241.3	63.5	190.5	149.4	104.6	25.8	2.0	8-22.5	200	512/419	11.2	44.0
3"	282.0	76.2	210.0	168.3	127.0	29.0	2.0	8-22.4	250	522/440	11.9	52.0
4"	305.0	101.6	255.0	200.0	157.2	32.2	2.0	8-22.4	300	615/512	12.7	76.0
6"	403.0	152.4	320.0	269.9	215.9	37.0	2.0	12-22.4	350	804/626	16.0	146.0
8"	419.0	203.2	380.0	330.2	269.9	41.7	2.0	12-25.4	400	1002/915	17.5	218.0
10"	457.0	254.0	445.0	387.4	323.8	48.1	2.0	16-28.6	450	1229/949	19.1	352.0
12"	502.0	304.8	520.0	450.8	381.0	51.3	2.0	16-32.0	460	1488/1112	20.6	478.0
14"	762.0	336.6	585.0	514.4	412.8	54.6	2.0	20-32.0	460	1182/1614	22.4	694.0
16"	838.0	387.4	650.0	571.5	469.9	57.6	2.0	20-35.0	460	1327/1809	23.9	1080.0
18"	914.0	431.8	710.0	628.6	533.4	60.8	2.0	24-35.0	540	1481/2031	25.4	1235.0
20"	991.0	482.6	775.0	685.8	584.2	64.0	2.0	24-35.0	540	1619/2219	26.9	1655.0
24"	1143.0	584.2	915.0	812.8	692.2	70.3	2.0	24-41.0	610	2004/2668	30.2	2320.0

*Please note dimensions are for information only. Order specific arrangement drawing dimensions will be final.

CAST STEEL GATE VALVES - ANSI 600

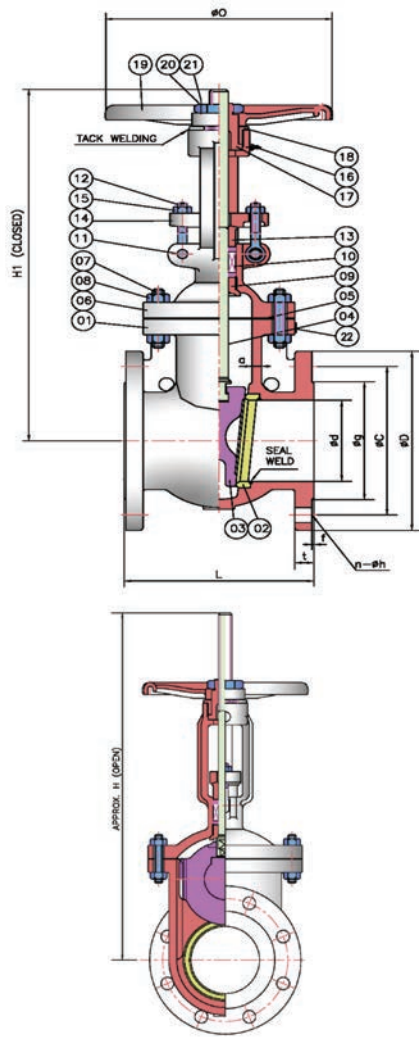

Parts And Material List			FIG . 0612F
No.	Part Name	Material	ASTM Specification
01	Body	Carbon Steel	ASTM A216 WCB
02	Body Seat Ring	Carbon Steel	ASTM A105 ST'L No. 6 Face
03	Wedge	Carbon Steel	ASTM A216 WCB 13Cr Face
04	Stem	Stainless Steel	ASTM A182 F6a
05	Gasket	Stainless Steel + Graphite	ASTM A182 316 + Graphite
06	Bonnet	Carbon Steel	ASTM A216 WCB
07	Bonnet Bolt	Carbon Steel	ASTM A193 B7
08	Bonnet Nut	Carbon Steel	ASTM A194 2H
09	Back Seat Ring	Stainless Steel	ASTM A276 410
10	Packing ring	Graphite	Die Formed / Braided Graphite
11	Hinge Pin	Carbon Steel	-
12	Gland Bolt	Carbon Steel	ASTM A193 B7
13	Packing Gland	Stainless Steel	ASTM A276 410
14	Gland Flange	Carbon Steel	ASTM A216 WCB
15	Gland Nut	Carbon Steel	ASTM A194 2H
16	Grease Nipple	Stainless Steel	2 1/2" and above
17	Yoke Sleeve	Ductile Iron	ASTM A439 D2
18	Yoke Cap	Carbon Steel	-
19	Handwheel	Ductile Iron	-
20	Handwheel Nut	Carbon Steel	-
21	Set Screw	Steel	-
22	Nameplate	Stainless Steel	ASTM A182 F316

OPERATOR OPTIONS

- Gear Operated recommended for size 8" above
- For Gear Dimensional detail contact KVC (UK) Ltd Engineering

SPECIFICATION

- Bolted Bonnet
 - Outside Screw and Yoke
 - Flexible Wedge
 - Oval Bonnet with integral Yoke
 - Rising Stem - Non-rising Handwheel
 - Welded-In / Threaded Seat Rings
 - Raised Face Flanged Ends or Butt Weld Ends
- Other End connections are available on request.

APPLICABLE STANDARDS

Design : API 600
 End Flange : ANSI B16.5
 Weld Ends : ANSI B16.25
 Face-to-Face : ANSI B16.10
 Shell and Seat Test : API 598

MATERIAL

Option available for materials to meet NACE MR0175 requirement.

Dimensional Data (mm)*												
Size	Face-to-Face L	Dia. of Bore d	O.D. of Flange D	ø of Bolt Circle C	O.D. of RF g	Thk of Flange t	Ht. of RF f	ø of Bolt Holes n-h	ø of Handwheel O	Height H/H1	Wall Thk a min	Wt (Kg)
2"	292.0	50.8	165.0	127.0	92.1	25.4	7.0	8-19.1	250	458/400	11.2	46.0
2-1/2"	330.2	63.5	190.5	149.4	104.6	28.5	7.0	8-22.5	250	475/403	11.9	55.0
3"	356.0	76.2	210.0	168.3	127.0	31.8	7.0	8-22.4	250	546/460	12.7	72.0
4"	432.0	101.6	275.0	215.9	157.2	38.1	7.0	8-25.4	350	680/570	16	128.0
6"	559.0	152.4	355.0	292.1	215.9	47.7	7.0	12-28.6	450	850/675	19.1	266.0
8"	660.0	199.9	420.0	349.2	269.9	55.6	7.0	12-32.0	310	1170/888	25.4	419.0
10"	787.0	247.7	510.0	431.8	323.8	63.5	7.0	16-35.0	460	1327/995	28.7	754.0
12"	838.0	298.5	560.0	489.0	381.0	66.7	7.0	20-35.0	540	1569/1169	31.8	981.0
14"	889.0	326.9	605.0	527.0	412.8	69.9	7.0	20-38.0	610	1762/1298	35.1	1316.0
16"	991.0	374.7	685.0	603.2	469.9	76.2	7.0	20-41.0	610	1905/1391	38.1	1672.0
18"	1092.0	419.1	745.0	654.0	533.4	82.6	7.0	20-44.0	610	2051/1487	41.4	2070.0
20"	1194.0	463.6	815.0	723.9	584.2	88.9	7.0	24-44.0	610	2320/1706	44.5	2405.0
24"	1397.0	558.8	939.8	838.2	692.2	101.6	7.0	24-52.0	810	2725/1937	50.8	4550.0

*Please note dimensions are for information only. Order specific arrangement drawing dimensions will be final.

CAST STEEL GATE VALVES - ANSI 900

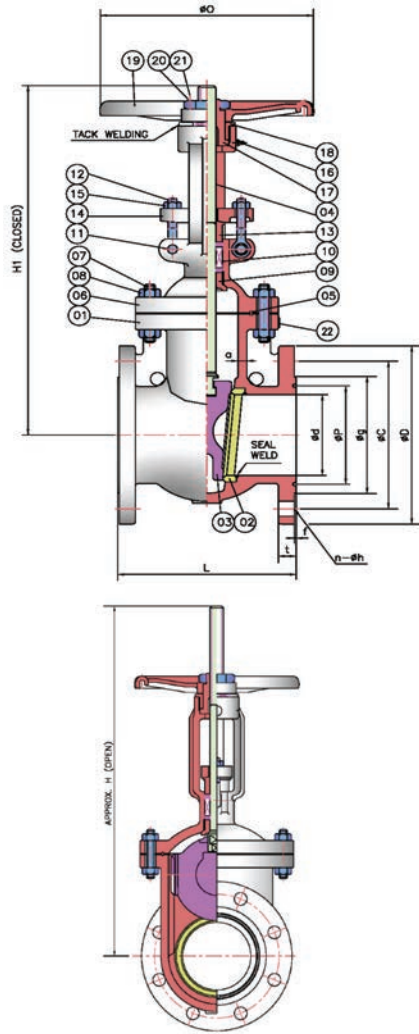

Parts And Material List			FIG . 0912R
No.	Part Name	Material	ASTM Specification
01	Body	Carbon Steel	ASTM A216 WCB
02	Body Seat Ring	Carbon Steel	ASTM A105 ST'L No. 6 Face
03	Wedge	Carbon Steel	ASTM A216 WCB 13Cr Face
04	Stem	Stainless Steel	ASTM A182 F6a
05	Gasket	Stainless Steel + Graphite	ASTM A182 316 + Graphite
06	Bonnet	Carbon Steel	ASTM A216 WCB
07	Bonnet Bolt	Carbon Steel	ASTM A193 B7
08	Bonnet Nut	Carbon Steel	ASTM A194 2H
09	Back Seat Ring	Stainless Steel	ASTM A276 410
10	Packing ring	Graphite	Die Formed / Braided Graphite
11	Hinge Pin	Carbon Steel	-
12	Gland Bolt	Carbon Steel	ASTM A193 B7
13	Packing Gland	Stainless Steel	ASTM A276 410
14	Gland Flange	Carbon Steel	ASTM A216 WCB
15	Gland Nut	Carbon Steel	ASTM A194 2H
16	Grease Nipple	Stainless Steel	2 1/2" and above
17	Yoke Sleeve	Ductile Iron	ASTM A439 D2
18	Yoke Cap	Carbon Steel	-
19	Handwheel	Ductile Iron	-
20	Handwheel Nut	Carbon Steel	-
21	Set Screw	Steel	-
22	Nameplate	Stainless Steel	ASTM A182 F316

OPERATOR OPTIONS

- Gear Operated recommended for size 6" above
- For Gear Dimensional detail contact KVC (UK) Ltd Engineering

SPECIFICATION

- Bolted Bonnet
 - Outside Screw and Yoke
 - Flexible Wedge
 - Oval Bonnet with integral Yoke
 - Rising Stem - Non-rising Handwheel
 - Welded-In / Threaded Seat Rings
 - Ring Type Joint or Butt Weld Ends
- Other End connections are available on request.

APPLICABLE STANDARDS

Design : API 600
 End Flange : ANSI B16.5
 Weld Ends : ANSI B16.25
 Face-to-Face : ANSI B16.10
 Shell and Seat Test : API 598

MATERIAL

Option available for materials to meet NACE MR0175 requirement.

Dimensional Data (mm)*													
Size	Face -to-Face L	Dia. of Bore d	O.D. of Flange D	ø of Bolt Circle C	O.D. of RF g	ø of RTJ p	Thk of Flange t	Ht. of RF f	ø of Bolt Holes n-h	ø of Handwheel O	Height H/H1	Wall Thk a min	Wt (Kg)
2"	371.0	47.5	215.0	165.1	124.0	95.3	38.1	7.9	8-25.4	300	465/394	19.1	95.0
3"	384.0	72.9	240.0	190.5	156.0	123.8	38.1	7.9	8-25.4	350	587/466	19.1	125.0
4"	460.2	98.3	290.0	235.0	180.8	149.2	44.5	7.9	8-32.0	350	690/495	21.3	192.0
6"	612.6	146.1	380.0	317.5	241.3	211.1	55.6	7.9	12-32.0	460	995/746	26.2	378.0
8"	739.6	190.5	470.0	393.7	307.8	269.9	63.5	7.9	12-38.0	460	1186/787	31.8	635.0
10"	841.2	238.0	545.0	469.9	362.0	323.9	69.9	7.9	16-38.0	540	1280/930	36.6	900.0
12"	968.2	282.4	610.0	533.4	419.1	381.0	79.4	7.9	20-38.0	540	1590/1095	42.2	1550.0

*Please note dimensions are for information only. Order specific arrangement drawing dimensions will be final.

CAST STEEL GATE VALVES - ANSI 1500

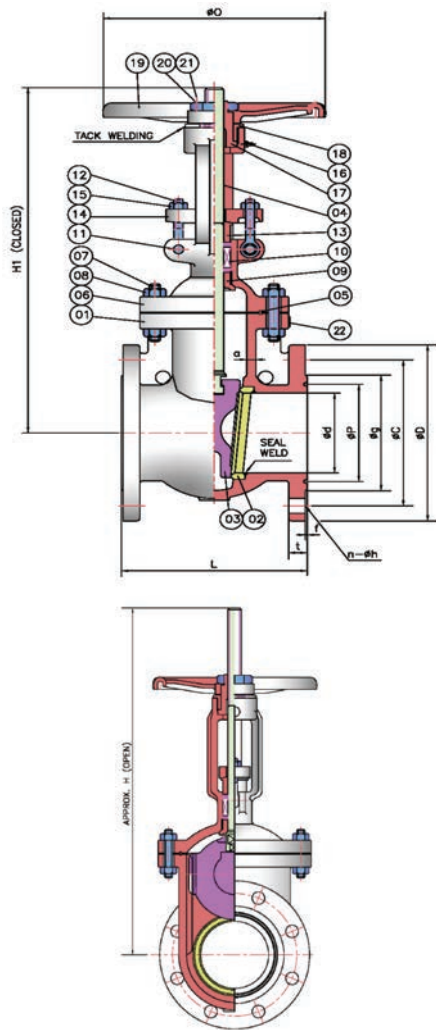

Parts And Material List			FIG . 1512R
No.	Part Name	Material	ASTM Specification
01	Body	Carbon Steel	ASTM A216 WCB
02	Body Seat Ring	Carbon Steel	ASTM A105 ST'L No. 6 Face
03	Wedge	Carbon Steel	ASTM A216 WCB 13Cr Face
04	Stem	Stainless Steel	ASTM A182 F6a
05	Gasket	Stainless Steel + Graphite	ASTM A182 316 + Graphite
06	Bonnet	Carbon Steel	ASTM A216 WCB
07	Bonnet Bolt	Carbon Steel	ASTM A193 B7
08	Bonnet Nut	Carbon Steel	ASTM A194 2H
09	Back Seat Ring	Stainless Steel	ASTM A276 410
10	Packing ring	Graphite	Die Formed / Braided Graphite
11	Hinge Pin	Carbon Steel	-
12	Gland Bolt	Carbon Steel	ASTM A193 B7
13	Packing Gland	Stainless Steel	ASTM A276 410
14	Gland Flange	Carbon Steel	ASTM A216 WCB
15	Gland Nut	Carbon Steel	ASTM A194 2H
16	Grease Nipple	Stainless Steel	2 1/2" and above
17	Yoke Sleeve	Ductile Iron	ASTM A439 D2
18	Yoke Cap	Carbon Steel	-
19	Handwheel	Ductile Iron	-
20	Handwheel Nut	Carbon Steel	-
21	Set Screw	Steel	-
22	Nameplate	Stainless Steel	ASTM A182 F316

OPERATOR OPTIONS

- Gear Operated recommended for size 4" above
- For Gear Dimensional detail contact KVC (UK) Ltd Engineering

SPECIFICATION

- Bolted Bonnet
 - Outside Screw and Yoke
 - Flexible Wedge
 - Oval Bonnet with integral Yoke
 - Rising Stem - Non-rising Handwheel
 - Welded-In / Threaded Seat Rings
 - Ring Type Joint or Butt Weld Ends
- Other End connections are available on request.

APPLICABLE STANDARDS

Design : API 600
 End Flange : ANSI B16.5
 Weld Ends : ANSI B16.25
 Face-to-Face : ANSI B16.10
 Shell and Seat Test : API 598

MATERIAL

Option available for materials to meet NACE MR0175 requirement.

Dimensional Data (mm)*													
Size	Face -to-Face L	Dia. of Bore d	O.D. of Flange D	ø of Bolt Circle C	O.D. of RF g	ø of RTJ P	Thk of Flange t	Ht. of RF f	ø of Bolt Holes n-h	ø of Handwheel O	Height H/H1	Wall Thk a min	Wt (Kg)
2"	371.3	47.5	215.0	165.1	124.0	95.3	38.1	7.9	8-25.4	300	614/524	19.1	95.0
3"	472.9	69.9	265.0	203.2	168.1	136.5	47.8	7.9	8-32.0	350	681/565	23.8	168.0
4"	549.1	91.9	310.0	241.3	193.5	161.9	53.8	7.9	8-35.0	400	702/582	28.5	277.0
6"	711.2	136.4	395.0	317.5	247.7	211.1	82.6	9.5	12-39.0	640	951/775	38.1	545.0
8"	841.5	177.8	485.0	393.7	317.5	269.9	91.9	11.1	12-45.0	710	1137/913	47.8	1180.0
10"	1000.3	222.3	585.0	482.6	371.3	323.9	108.0	11.1	12-51.0	750	1437/1170	57.1	2118.0

*Please note dimensions are for information only. Order specific arrangement drawing dimensions will be final.

CAST STEEL GATE VALVES - ANSI 1500 PRESSURE SEAL BONNET

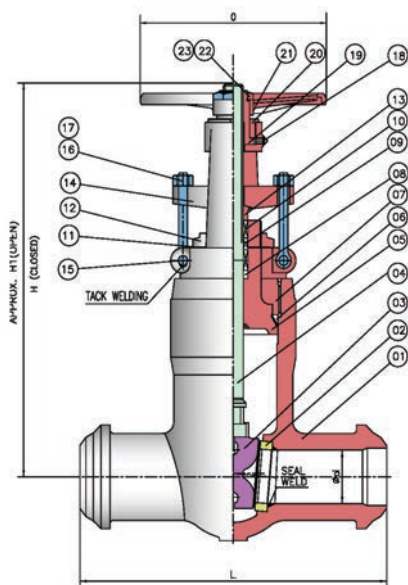

OPERATOR OPTIONS

- Gear Operated recommended for size 4" above
- For Gear Dimensional detail contact KVC (UK) Ltd Engineering

SPECIFICATION

- Pressure Seal Bonnet
- Outside Screw and Yoke
- Flexible Wedge
- Oval Bonnet with integral Yoke
- Rising Stem - Non-rising Handwheel
- Welded-In / Threaded Seat Rings
- Butt Weld Ends

Other End connections are available on request.

APPLICABLE STANDARDS

Design : API 600
End Flange : ANSI B16.5
Weld Ends : ANSI B16.25
Face-to-Face : ANSI B16.10
Shell and Seat Test : API 598

MATERIAL

Option available for materials to meet NACE MR0175 requirement.

Parts And Material List FIG . 1552B

No.	Part Name	Material	ASTM Specification
01	Body	Carbon Steel	ASTM A216 WCB
02	Body Seat Ring	Carbon Steel	ASTM A105 ST'L No. 6 Face
03	Wedge	Carbon Steel	ASTM A216 WCB ST'L No.6 Face
04	Stem	Stainless Steel	ASTM A182 F6a
05	Stuffing Box	Carbon Steel	ASTM A105
06	Sealing Ring	Stainless Steel	ASTM A276 316L
07	Yoke	Carbon Steel	ASTM A216 WCB
08	Spacer Ring	Stainless Steel	ASTM A276 410
09	Lantern	Stainless Steel	ASTM A276 410
10	Packing Ring	Graphite	Die Formed / Braided Graphite
11	Nut Gasket	Stainless Steel	ASTM A276 410
12	Stuffing Nut	Carbon Steel	ASTM A193 B7
13	Gland	Stainless Steel	ASTM A276 410
14	Gland Flange	Carbon Steel	ASTM A216 WCB
15	Hinge Pin	Carbon Steel	-
16	Gland Eye Bolt	Carbon Steel	ASTM A193 B7
17	Gland Nut	Carbon Steel	ASTM A194 2H
18	Grease Nipple	Stainless Steel	-
19	Yoke Sleeve	Ductile Iron	ASTM A439 D2
20	Yoke Cap	Carbon Steel	-
21	Handwheel	Malleable Iron	-
22	Handwheel Nut	Carbon Steel	-
23	Set Screw	Steel	-

Dimensional Data (mm)*

Size	Face -to-Face L	Dia. of Bore d	o of Handwheel O	Height H/H1	Wall Thk a min	Wt (Kg)
2"	216.0	47.5	300	614/524	19.1	95.0
3"	305.0	69.9	350	681/565	23.9	168.0
4"	406.0	91.9	400	702/582	28.7	277.0
6"	559.0	136.4	640	951/775	38.1	545.0
8"	711.0	177.8	710	1137/913	47.8	1180.0
10"	864.0	222.3	750	1437/1170	57.1	2118.0
12"	991.0	263.4	800	1834/1554	66.8	2800.0

* Please note dimensions are for information only. Order specific arrangement drawing dimensions will be final.



GLOBE VALVES

Globe Valves are used where throttling and shut off are required. Close throttling can lead to altered velocities, this leads to excessive noise and vibration which can damage the valve or piping system.

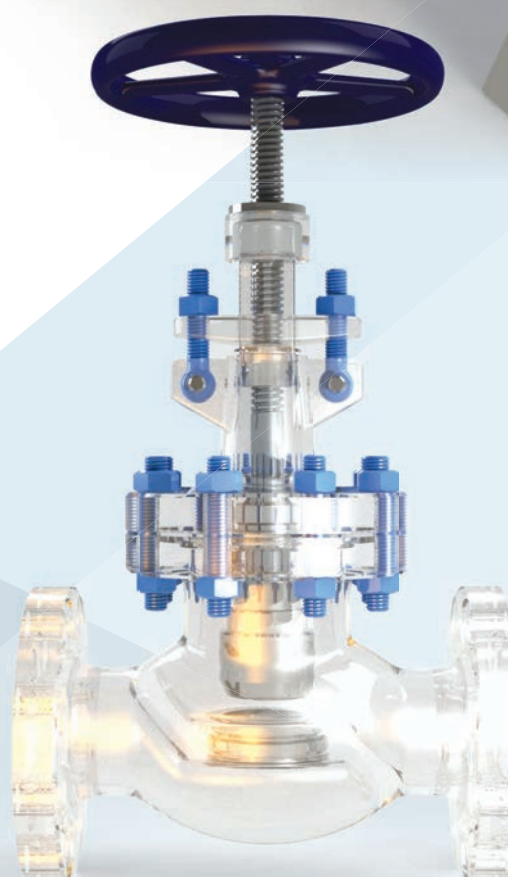

CAST STEEL GLOBE VALVES

KVC (UK) LTD Globe valves are manufactured to BS 1873, B16.34 and tested to API Std.598

Globe Valves are used where throttling and shut off are required. They can also be used for on-off service, but due to high pressure drop, this is generally confined to applications where the valve is normally closed and pressure drop is not important when the valve is open. Close throttling can lead to altered velocities, this leads to excessive noise and vibration which can damage the valve or piping system.

BODY AND BONNET

- Back-Seat Bushing
- Gland can be Re-packed in-situ
- Spherical body with large radius, allows stress and turbulence to be minimised

BODY-BONNET JOINT / GASKET

- Range of materials to suit Pressure Classes

DISC

- Valves are supplied with plug type disc as shown



WELDED-IN SEAT RING

- Seat ring is seal welded to eliminate potential leak paths.

STEM

- One piece stem, forged tee-head connection
- Rolled or cut ACME threads subject to valve size
- Polished on the packing contact area
- Ensures long life & optimal tightness
- Engineered stem break-point above packing area
- Ensures sealing integrity to atmosphere.

GLAND

- The Gland Flange & Packing Gland are manufactured in two separate pieces
- Adjustable gland in service
- Optional live loaded gland can be specified
- Backseated design allowing the gland packing to be replaced in situ.

STUFFING BOX

- Packing contains corrosion inhibitor to avoid stem pitting.
- Deep stuffing box design ensures long packing life.



END CONNECTIONS

- As Standard production covers valves with:

Flanged ends to ANSI B16.5

RF Raised face serrated finish or,

On request, with any other type of finish

RTJ Ring Type Joint

Others

Butt-welding ends (BW) to ANSI B16.25

- Customer must specify the type of schedule required, or class of pipe, or diameter and bore.

Special end connections on request.

FACE to FACE

- Face to Face dimensions to ANSI B16.10.

HANDWHEEL

- Handwheels designed for ease of operation.

GEAR OPERATED VALVES

- Valves can be supplied with bevel gear operators

MOTOR OPERATED VALVES

- On request valves can be supplied equipped with, or prepared for actuators
- Electric /
- Pneumatic /
- Hydraulic (according to customers' requirements).

- Customer is to advise all service requirements and applicable specification with enquiry.

ACCESSORIES

- OnRequest:
- By-passes, locking devices, chain wheels, floor stands, special extension stems and others.

TESTING

- Standard Testing is in accordance with API 598.
- Customer specific testing by agreement.

CAST STEEL GLOBE VALVE - ANSI 150

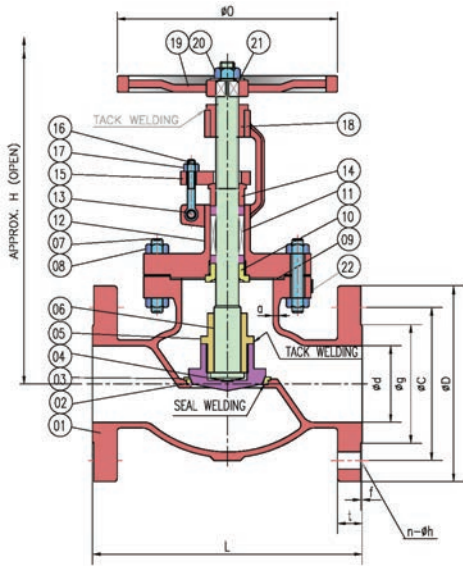

Parts And Material List FIG . 0122F

No.	Part Name	Material	ASTM Specification
01	Body	Carbon Steel	ASTM A216 Gr. WCB
02	Body Seat Ring	Carbon Steel	ASTM A105 ST*L No.6 Face
03	Disc	Carbon Steel	ASTM A105 13Cr Face
04	Disc Thrust Plate	Stainless Steel	A276 410
05	Disc Nut	Stainless Steel	A276 410
06	Stem	Stainless Steel	ASTM A182 F6a
07	Bonnet Bolt	Carbon Steel	ASTM A193 B7
08	Bonnet Nut	Carbon Steel	ASTM A194 2H
09	Gasket	Stainless Steel	Spiral Wound 316 + Graphite
10	Back Seat Ring	Stainless Steel	A276 410
11	Packing Ring	Graphite	Die Formed/Braided Graphite
12	Bonnet	Carbon Steel	ASTM A216 Gr. WCB
13	Hinge Pin	Carbon Steel	Carbon Steel
14	Packing Gland	Stainless Steel	ASTM A276 410
15	Gland Flange	Carbon Steel	ASTM A216 WCB
16	Gland Bolt	Carbon Steel	ASTM A193 B7
17	Gland Nut	Carbon Steel	ASTM A194 2H
18	Yoke Bush	Ductile Iron	ASTM A439 D2
19	Handwheel	Malleable Iron	Malleable Iron
20	Handwheel Nut	Carbon Steel	Carbon Steel
21	Washer	Carbon Steel	Carbon Steel
22	Nameplate	Stainless Steel	ASTM A182 F316

OPERATOR OPTIONS

- Gear Operated recommended for size 12" above
- For Gear Dimensional detail contact KVC (UK) Ltd

SPECIFICATION

- Bolted Bonnet
- Outside Screw and Yoke
- Yoke integral with bonnet
- Rising Stem - Handwheel
- Welded or Threaded Seat Ring - Stellite
- Raised Face Flanged Ends or Butt Weld Ends

Other End connections are available on request.

APPLICABLE STANDARDS

Design : ANSI B16.34
 End Flange : ANSI B16.5
 Weld Ends : ANSI B16.25
 Face-to-Face : ANSI B16.10
 Shell and Seat Test : API 598

MATERIAL

Option available for materials to meet NACE MR0175 requirement.

Dimensional Data (mm)*												
Size	Face-to-Face L	Dia. of Bore d	O.D. of Flange D	ø of Bolt Circle C	O.D. of RF g	Thk of Flange t	Ht. of RF f	ø of Bolt Holes n-h	ø of Handwheel O	Height H	Wall Thk a min	Wt (Kg)
2"	203.0	50.8	150.0	120.7	92.1	16.3	2.0	4-19.1	200	350	8.6	22.0
2-1/2"	216.0	64.0	178.0	139.5	105.0	19.5	2.0	4-19.1	250	403	9.7	30.0
3"	241.0	76.2	190.0	152.4	127.0	19.5	2.0	4-19.1	250	405	10.4	42.0
4"	292.0	101.6	230.0	190.5	157.2	24.3	2.0	8-19.1	300	478	11.2	60.0
6"	406.0	152.4	280.0	241.3	215.9	25.9	2.0	8-22.4	350	513	11.9	101.0
8"	495.0	203.2	345.0	298.5	269.7	29.0	2.0	8-22.4	450	610	12.7	161.0
10"	622.0	254.0	405.0	362.0	323.8	30.6	2.0	12-25.4	450	730	14.2	308.0
12"	698.0	304.8	485.0	431.8	381.0	32.0	2.0	12-25.4	610	923	16.0	410.0

* Please note dimensions are for information only. Order specific arrangement drawing dimensions will be final.

CAST STEEL GLOBE VALVE - ANSI 300

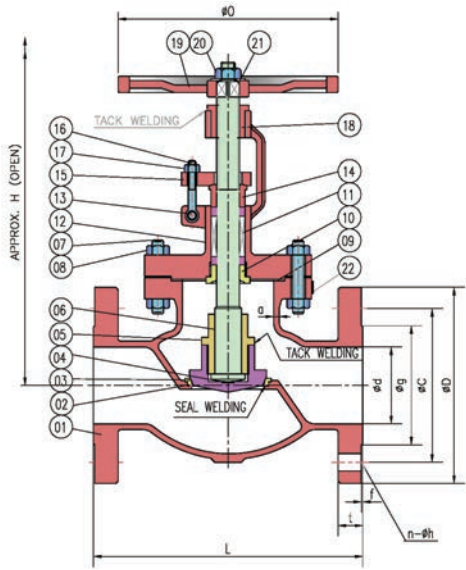

OPERATOR OPTIONS

- Gear Operated recommended for size 10" above
- For Gear Dimensional detail contact KVC (UK) Ltd

SPECIFICATION

- Bolted Bonnet
- Outside Screw and Yoke
- Yoke integral with bonnet
- Rising Stem - Handwheel
- Welded or Threaded Seat Ring - Stellite
- Raised Face Flanged Ends or Butt Weld Ends

Other End connections are available on request.

Parts And Material List FIG . 0322F

No.	Part Name	Material	ASTM Specification
01	Body	Carbon Steel	ASTM A216 Gr. WCB
02	Body Seat Ring	Carbon Steel	ASTM A105 ST*L No.6 Face
03	Disc	Carbon Steel	ASTM A105 13Cr Face
04	Disc Thrust Plate	Stainless Steel	A276 410
05	Disc Nut	Stainless Steel	A276 410
06	Stem	Stainless Steel	ASTM A182 F6a
07	Bonnet Bolt	Carbon Steel	ASTM A193 B7
08	Bonnet Nut	Carbon Steel	ASTM A194 2H
09	Gasket	Stainless Steel	Spiral Wound 316 + Graphite
10	Back Seat Ring	Stainless Steel	A276 410
11	Packing Ring	Graphite	Die Formed/Braided Graphite
12	Bonnet	Carbon Steel	ASTM A216 Gr. WCB
13	Hinge Pin	Carbon Steel	Carbon Steel
14	Packing Gland	Stainless Steel	ASTM A276 410
15	Gland Flange	Carbon Steel	ASTM A216 WCB
16	Gland Bolt	Carbon Steel	ASTM A193 B7
17	Gland Nut	Carbon Steel	ASTM A194 2H
18	Yoke Bush	Ductile Iron	ASTM A439 D2
19	Handwheel	Malleable Iron	Malleable Iron
20	Handwheel Nut	Carbon Steel	Carbon Steel
21	Washer	Carbon Steel	Carbon Steel
22	Nameplate	Stainless Steel	ASTM A182 F316

APPLICABLE STANDARDS

Design : ANSI B16.34
 End Flange : ANSI B16.5
 Weld Ends : ANSI B16.25
 Face-to-Face : ANSI B16.10
 Shell and Seat Test : API 598

MATERIAL

Option available for materials to meet NACE MR0175 requirement.

Dimensional Data (mm)*												
Size	Face-to-Face L	Dia. of Bore d	O.D. of Flange D	ø of Bolt Circle C	O.D. of RF g	Thk of Flange t	Ht. of RF f	ø of Bolt Holes n-h	ø of Handwheel O	Height H	Wall Thk a min	Wt (Kg)
2"	267.0	50.8	165.0	127.0	92.1	22.7	2.0	8-19.1	200	384	9.7	31.0
2-1/2"	292.0	63.5	190.5	149.4	104.6	25.9	2.0	8-22.5	250	412	11.2	40.0
3"	318.0	76.2	210.0	168.3	127.0	29.0	2.0	8-22.4	300	438	11.9	58.0
4"	356.0	101.6	255.0	200.0	157.2	32.2	2.0	8-22.4	350	556	12.7	86.0
6"	444.0	152.4	320.0	269.9	215.9	37.0	2.0	12-22.4	450	632	16	150.0
8"	559.0	203.2	380.0	330.2	269.9	41.7	2.0	12-25.4	450	1002	17.5	397.0
10"	622.0	254.0	445.0	387.4	323.8	48.1	2.0	16-28.6	560	1078	19.1	527.0
12"	711.0	304.8	520.0	450.8	381.0	51.3	2.0	16-32.0	650	1100	20.7	608.0

* Please note dimensions are for information only. Order specific arrangement drawing dimensions will be final.

CAST STEEL GLOBE VALVE - ANSI 600

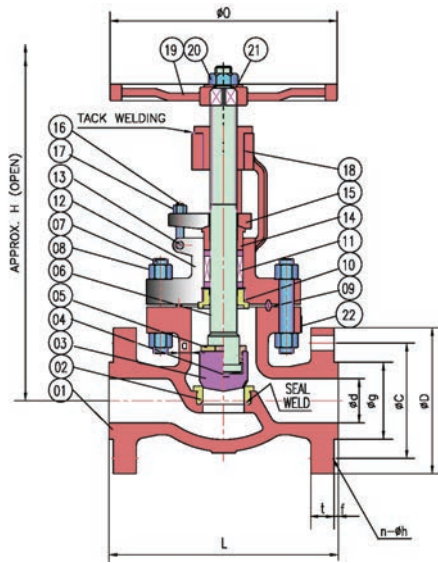

Parts And Material List FIG . 0622F

No.	Part Name	Material	ASTM Specification
01	Body	Carbon Steel	ASTM A216 Gr. WCB
02	Body Seat Ring	Carbon Steel	ASTM A105 ST*L No.6 Face
03	Disc	Carbon Steel	ASTM A105 13Cr Face
04	Disc Thrust Plate	Stainless Steel	A276 410
05	Disc Nut	Stainless Steel	A276 410
06	Stem	Stainless Steel	ASTM A182 F6a
07	Bonnet Bolt	Carbon Steel	ASTM A193 B7
08	Bonnet Nut	Carbon Steel	ASTM A194 2H
09	Gasket	Stainless Steel	Spiral Wound 316 + Graphite
10	Back Seat Ring	Stainless Steel	A276 410
11	Packing Ring	Graphite	Die Formed/Braided Graphite
12	Bonnet	Carbon Steel	ASTM A216 Gr. WCB
13	Hinge Pin	Carbon Steel	Carbon Steel
14	Packing Gland	Stainless Steel	ASTM A276 410
15	Gland Flange	Carbon Steel	ASTM A216 WCB
16	Gland Bolt	Carbon Steel	ASTM A193 B7
17	Gland Nut	Carbon Steel	ASTM A194 2H
18	Yoke Bush	Ductile Iron	ASTM A439 D2
19	Handwheel	Malleable Iron	Malleable Iron
20	Handwheel Nut	Carbon Steel	Carbon Steel
21	Washer	Carbon Steel	Carbon Steel
22	Nameplate	Stainless Steel	ASTM A182 F316

OPERATOR OPTIONS

- Gear Operated recommended for size 6" above
- For Gear Dimensional detail contact KVC (UK) Ltd

SPECIFICATION

- Bolted Bonnet
- Outside Screw and Yoke
- Yoke integral with bonnet
- Rising Stem - Handwheel
- Welded or Threaded Seat Ring - Stellite
- Raised Face Flanged Ends or Butt Weld Ends

Other End connections are available on request.

APPLICABLE STANDARDS

Design : ANSI B16.34
 End Flange : ANSI B16.5
 Weld Ends : ANSI B16.25
 Face-to-Face : ANSI B16.10
 Shell and Seat Test : API 598

MATERIAL

Option available for materials to meet NACE MR0175 requirement.

Dimensional Data (mm)*												
Size	Face -to-Face L	Dia. of Bore d	O.D. of Flange D	ø of Bolt Circle C	O.D. of RF g	Thk of Flange t	Ht. of RF f	ø of Bolt Holes n-h	ø of Handwheel O	Height H	Wall Thk a min	Wt (Kg)
2"	292.0	50.8	165.0	127.0	92.1	25.4	7.0	8-19.1	250	430	11.2	57.0
3"	356.0	76.2	210.0	168.3	127.0	31.8	7.0	8-22.5	350	530	12.7	89.0
4"	432.0	101.6	275.0	215.9	157.2	38.1	7.0	8-25.4	450	620	16	149.0
6"	559.0	152.4	355.0	292.1	215.9	47.7	7.0	12-28.6	500	886	19.1	417.0
8"	660.0	199.9	420.0	349.3	269.9	55.6	7.0	12-32.0	560	932	25.4	542.0
10"	787.0	247.7	510.0	431.8	323.8	63.5	7.0	16-35.0	720	1040	28.7	700.0
12"	838.0	298.5	560.0	489.0	381.0	66.7	7.0	20-35.0	720	1060	31.8	1105.0

* Please note dimensions are for information only. Order specific arrangement drawing dimensions will be final.

CAST STEEL GLOBE VALVE - ANSI 900

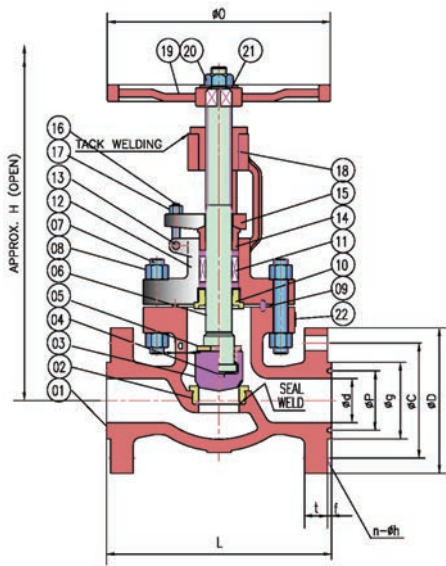

OPERATOR OPTIONS

- Gear Operated recommended for size 6" above
- For Gear Dimensional detail contact KVC (UK) Ltd Engineering

SPECIFICATION

- Bolted Bonnet
 - Outside Screw and Yoke
 - Yoke integral with bonnet
 - Rising Stem - Handwheel
 - Welded or Threaded Seat Ring - Stellite
 - Ring Type Joint or Butt Weld Ends
- Other End connections are available on request.

Parts And Material List

FIG . 0922R

No.	Part Name	Material	ASTM Specification
01	Body	Carbon Steel	ASTM A216 Gr. WCB
02	Body Seat Ring	Carbon Steel	ASTM A105 ST*L No.6 Face
03	Disc	Carbon Steel	ASTM A105 13Cr Face
04	Disc Thrust Plate	Stainless Steel	A276 410
05	Disc Nut	Stainless Steel	A276 410
06	Stem	Stainless Steel	ASTM A182 F6a
07	Bonnet Bolt	Carbon Steel	ASTM A193 B7
08	Bonnet Nut	Carbon Steel	ASTM A194 2H
09	Gasket	Stainless Steel	Spiral Wound 316 + Graphite
10	Back Seat Ring	Stainless Steel	A276 410
11	Packing Ring	Graphite	Die Formed/Braided Graphite
12	Bonnet	Carbon Steel	ASTM A216 Gr. WCB
13	Hinge Pin	Carbon Steel	Carbon Steel
14	Packing Gland	Stainless Steel	ASTM A276 410
15	Gland Flange	Carbon Steel	ASTM A216 WCB
16	Gland Bolt	Carbon Steel	ASTM A193 B7
17	Gland Nut	Carbon Steel	ASTM A194 2H
18	Yoke Bush	Ductile Iron	ASTM A439 D2
19	Handwheel	Malleable Iron	Malleable Iron
20	Handwheel Nut	Carbon Steel	Carbon Steel
21	Washer	Carbon Steel	Carbon Steel
22	Nameplate	Stainless Steel	ASTM A182 F316

APPLICABLE STANDARDS

Design : ANSI B16.34
 End Flange : ANSI B16.5
 Weld Ends : ANSI B16.25
 Face-to-Face : ANSI B16.10
 Shell and Seat Test : API 598

MATERIAL

Option available for materials to meet NACE MR0175 requirement.

Dimensional Data (mm)*

Size	Face-to-Face L	Dia. of Bore d	O.D. of Flange D	ø of Bolt Circle C	O.D. of RF g	ø of RTJ P	Thk of Flange t	Ht. of RF f	ø of Bolt Holes n-h	ø of Handwheel O	Height H	Wall Thk a min	Wt (Kg)
2"	368.0	47.5	215.0	165.1	124.0	95.3	38.1	7.0	8-25.4	350	485	19.1	87.0
3"	381.0	72.9	240.0	190.5	156.0	123.8	38.1	7.0	8-25.4	450	595	19.1	122.0
4"	457.0	98.3	290.0	235.0	181.0	149.2	44.5	7.0	8-32.0	450	760	21.3	182.0
6"	610.0	146.1	380.0	317.5	241.0	211.1	55.6	7.0	12-32.0	560	890	26.2	434.0
8"	737.0	190.5	470.0	393.7	308.0	269.9	63.5	7.0	12-38.0	720	910	31.8	730.0
10"	838.0	238.0	545.0	469.9	362.0	323.9	69.9	7.0	16-38.0	810	1278	36.6	1231.0

* Please note dimensions are for information only. Order specific arrangement drawing dimensions will be final.

CAST STEEL GLOBE VALVE - ANSI 1500

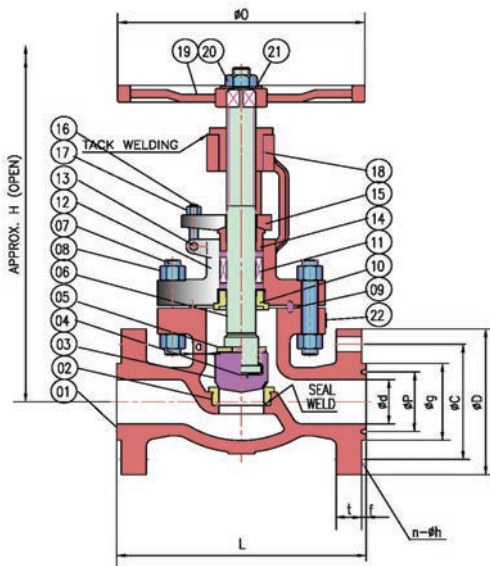

Parts And Material List FIG . 1522R

No.	Part Name	Material	ASTM Specification
01	Body	Carbon Steel	ASTM A216 Gr. WCB
02	Body Seat Ring	Carbon Steel	ASTM A105 ST*L No.6 Face
03	Disc	Carbon Steel	ASTM A105 13Cr Face
04	Disc Thrust Plate	Stainless Steel	A276 410
05	Disc Nut	Stainless Steel	A276 410
06	Stem	Stainless Steel	ASTM A182 F6a
07	Bonnet Bolt	Carbon Steel	ASTM A193 B7
08	Bonnet Nut	Carbon Steel	ASTM A194 2H
09	Gasket	Stainless Steel	Spiral Wound 316 + Graphite
10	Back Seat Ring	Stainless Steel	A276 410
11	Packing Ring	Stainless Steel	316 SS Ring Joint
12	Bonnet	Carbon Steel	ASTM A216 Gr. WCB
13	Hinge Pin	Carbon Steel	Carbon Steel
14	Packing Gland	Stainless Steel	ASTM A276 410
15	Gland Flange	Carbon Steel	ASTM A216 WCB
16	Gland Bolt	Carbon Steel	ASTM A193 B7
17	Gland Nut	Carbon Steel	ASTM A194 2H
18	Yoke Bush	Ductile Iron	ASTM A439 D2
19	Handwheel	Malleable Iron	Malleable Iron
20	Handwheel Nut	Carbon Steel	Carbon Steel
21	Washer	Carbon Steel	Carbon Steel
22	Nameplate	Stainless Steel	ASTM A182 F316

OPERATOR OPTIONS

- Gear Operated recommended for size 4" above
- For Gear Dimensional detail contact KVC (UK) Ltd

SPECIFICATION

- Bolted Bonnet
 - Outside Screw and Yoke
 - Yoke integral with bonnet
 - Rising Stem - Handwheel
 - Welded or Threaded Seat Ring - Stellite
 - Ring Type Joint or Butt Weld Ends
- Other End connections are available on request.

APPLICABLE STANDARDS

Design : ANSI B16.34
 End Flange : ANSI B16.5
 Weld Ends : ANSI B16.25
 Face-to-Face : ANSI B16.10
 Shell and Seat Test : API 598

MATERIAL

Option available for materials to meet NACE MR0175 requirement.

Dimensional Data (mm)*													
Size	Face-to-Face L	Dia. of Bore d	O.D. of Flange D	ø of Bolt Circle C	O.D. of RF g	ø of RTJ P	Thk of Flange t	Ht. of RF f	ø of Bolt Holes n-h	ø of Handwheel O	Height H	Wall Thk a min	Wt (Kg)
2"	371.3	49.5	215.0	165.1	124.0	95.3	38.1	7.9	8-25.4	350	650	19.1	87.0
3"	472.9	69.9	265.0	203.2	168.1	136.5	47.7	7.9	8-32.0	450	711	23.9	250.0
4"	549.1	91.9	310.0	241.3	193.5	161.9	54.0	7.9	8-35.0	560	782	28.7	435.0
6"	711.2	136.4	395.0	315	247.7	211.1	82.6	9.5	12-38.0	640	927	38.1	540.0

* Please note dimensions are for information only. Order specific arrangement drawing dimensions will be final.

CAST STEEL GLOBE VALVE - ANSI 1500 PRESSURE SEAL BONNET

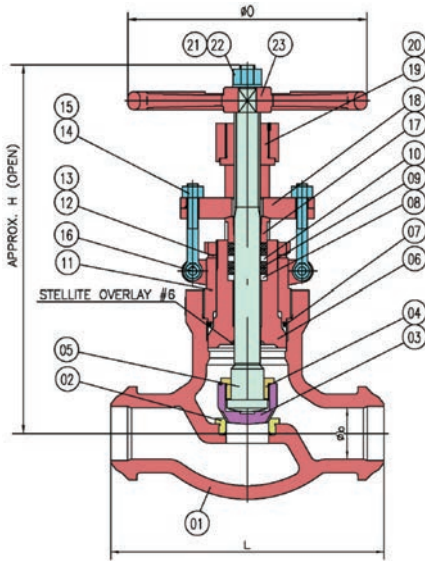

OPERATOR OPTIONS

- Gear Operated recommended for size 4" above 4" above
- For Gear Dimensional detail contact KVC (UK) Ltd Engineering

SPECIFICATION

- Pressure Seal Bonnet
- Outside Screw and Yoke
- Yoke integral with bonnet
- Rising Stem - Handwheel
- Welded or Threaded Seat Ring - Stellite
- Butt Weld Ends

Other End connections are available on request.

APPLICABLE STANDARDS

Design : ANSI B16.34
End Flange : ANSI B16.5
Weld Ends : ANSI B16.25
Face-to-Face : ANSI B16.10
Shell and Seat Test : API 598

MATERIAL

Option available for materials to meet NACE MR0175 requirement.

Parts And Material List FIG . 1562B

No.	Part Name	Material	ASTM Specification
01	Body	Carbon Steel	ASTM A216 Gr. WCB
02	Body Seat Ring	Carbon Steel	ASTM A105 ST'L No.6 Face
03	Disc	Carbon Steel	ASTM A105 ST'L No.6 Face
04	Disc Nut	Stainless Steel	ASTM A276 410
05	Stem	Stainless Steel	ASTM A182 F6a
06	Stuffing Box	Carbon Steel	ASTM A105
07	Sealing Ring	Stainless Steel	ASTM A276 316L
08	Spacer Ring	Stainless Steel	ASTM A276 410
09	Packing Ring	Graphite	Die Formed/Braided Graphite
10	Lantern	Stainless Steel	ASTM A276 410
11	Yoke	Carbon Steel	ASTM A216 WCB
12	Gland Seat	Carbon Steel	-
13	Gland Seat Washer	Stainless Steel	ASTM A276 410
14	Gland	Stainless Steel	ASTM A276 410
15	Gland Flange	Carbon Steel	ASTM A216 Gr. WCB
16	Hinge Pin	Carbon Steel	-
17	Gland Bolt	Carbon Steel	ASTM A193 B7
18	Gland Nut	Carbon Steel	ASTM A194 2H
19	Yoke Bush	Ductile Iron	ASTM A439 D2
20	Set Screw	Steel	-
21	Handwheel	Malleable Iron	Malleable Iron
22	Handwheel Nut	Carbon Steel	-
23	Washer	Carbon Steel	-

Dimensional Data (mm)*						
Size	Face -to-Face L	Dia. of Bore d	ø of Handwheel O	Height H	Wall Thk a min	Wt (Kg)
2"	216.0	47.5	350	650	19.1	87.0
3"	305.0	69.9	450	711	23.9	250.0
4"	406.0	91.9	560	782	28.7	435.0
6"	559.0	136.4	640	927	38.1	540.0
8"	711.0	177.8	720	1127	47.8	760.0
10"	864.0	222.3	900	1308	57.2	940.0

* Please note dimensions are for information only. Order specific arrangement drawing dimensions will be final.

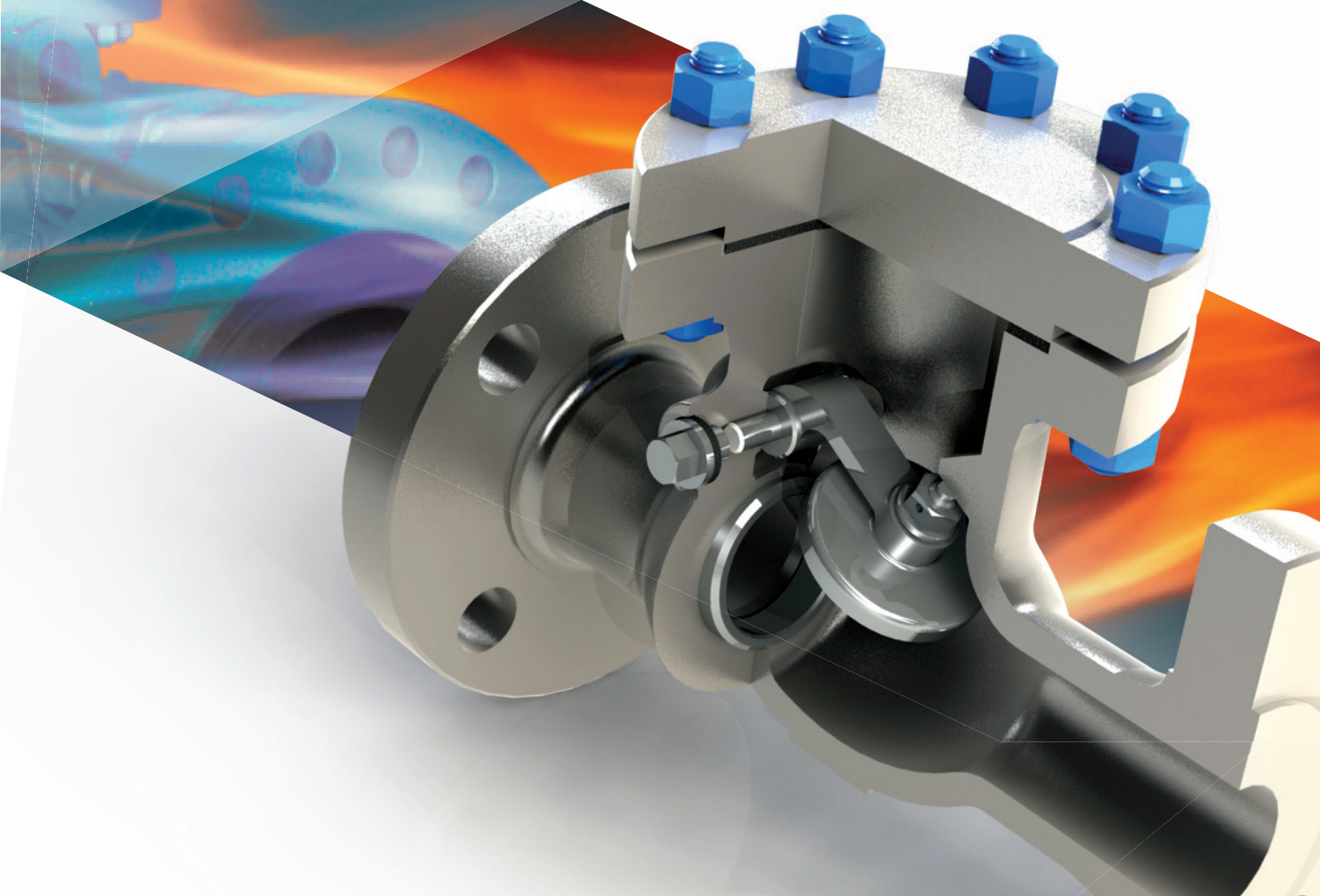

SWING CHECK VALVES

Swing Check valves are automatically actuated. They are used to prevent flow reversal in piping systems.

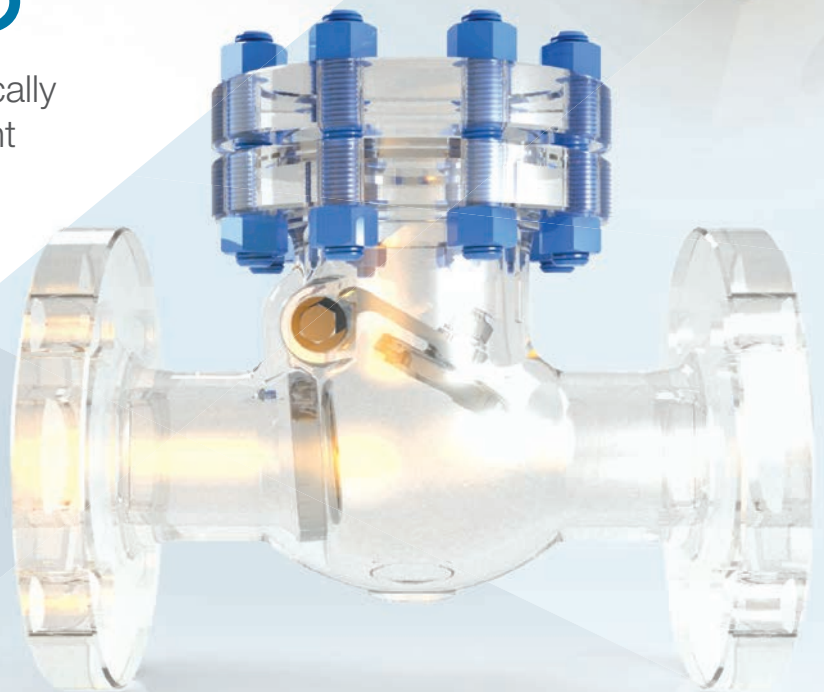

CAST STEEL SWING CHECK VALVES

KVC (UK) LTD Swing Check valves are manufactured to BS 1868, B16.34, and tested to API Std.598

Swing Check valves are automatically actuated. They are used to prevent flow reversal in piping systems. They are suitable for service in the horizontal and the vertical orientation (flow up through valve). Swing check valves have low pressure drop characteristics and are best suited for moderate velocity applications. There is no tendency for the seating surfaces of swing check valves to gall or score, this is due to the fact that the disc meets the flat seat squarely and there is no rubbing upon contact.

BODY

Spherical body with large radius, allows stress and turbulence to be minimized
Strong construction assures safety, even above pressure and temperature limits.

BODY-BONNET JOINT / GASKET

Range of materials to suit Pressure Classes

DISC

Designed to close on its own weight to stop backflow.

WELDED-INSEAT RING

Seat ring is seal welded to eliminate potential leak paths.

END CONNECTIONS

As Standard production covers valves with:

Flanged ends to ANSI B16.5

RF Raised face serrated finish or,

On request, with any other type of finish

RTJ Ring Type Joint

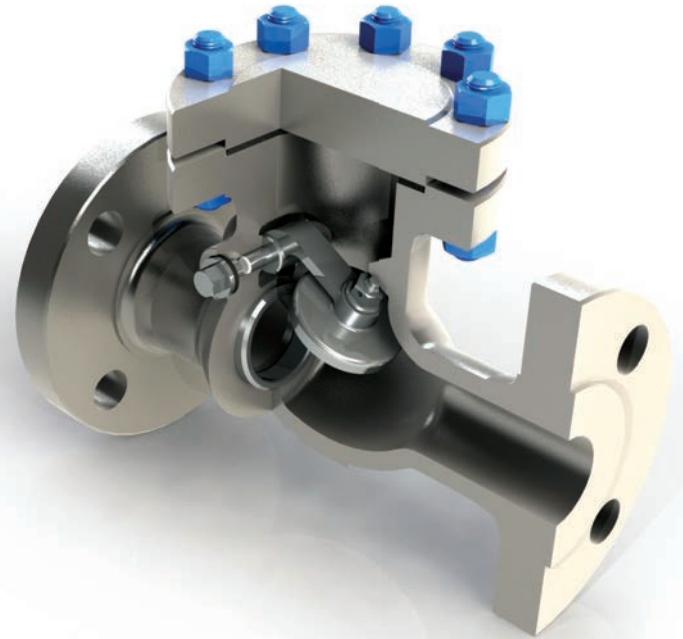

Others

Butt-welding ends (BW) to ANSI B16.25

Customer must specify the type of schedule required, or class of pipe, or diameter and bore.

Special end connections on request.

FACE to FACE

Face to Face dimensions to ANSI B16.10.

TESTING

Standard Testing is in accordance with API 598.

Customer specific testing by agreement.

CAST STEEL SWING CHECK VALVE - ANSI 150

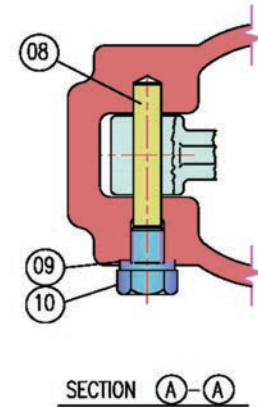
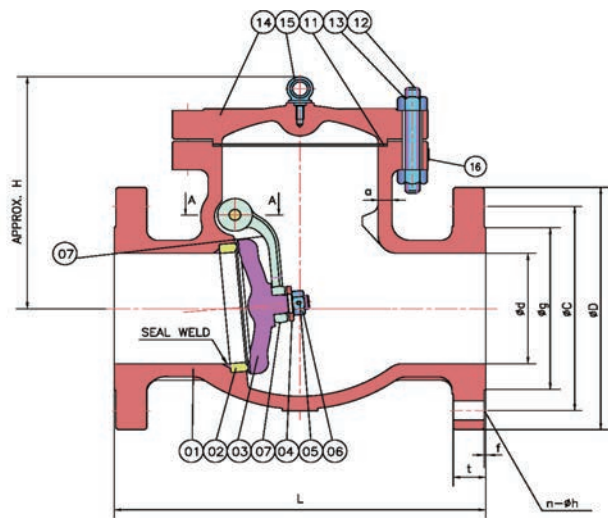

Parts And Material List **FIG . 0132F**

No.	Part Name	Material	ASTM Specification
01	Body	Carbon Steel	ASTM A216 Gr. WCB
02	Body Seat Ring	Carbon Steel	ASTM A105 ST'L No.6 Face
03	Disc	Carbon Steel	ASTM A216 13Cr Face
04	Washer	Carbon Steel	ASTM A276 316
05	Disc Nut Pin	Stainless Steel	ASTM A276 410
06	Disc Nut	Carbon Steel	ASTM A194 8
07	Arm	Carbon Steel	ASTM A216 WCB
08	Arm Pin	Stainless Steel	ASTM A276 410
09	Spring Washer	Stainless Steel	ASTM A276 316
10	Plug	Stainless Steel	ASTM A276 410
11	Gasket	Stainless Steel	Spiral Wound 316+Graphite
12	Cover Bolt	Carbon Steel	ASTM A193 B7
13	Cover Bolt Nut	Carbon Steel	ASTM A194 2H
14	Cover	Carbon Steel	ASTM A216 WCB
15	Eye Bolt	Carbon Steel	Carbon Steel
16	Nameplate	Stainless Steel	ASTM A182 F316

SPECIFICATION

- Bolted Cover
- For Horizontal or Vertical Lines (Up Flow Only)
- Welded or Threaded Seat Ring
- Raised Face Flanged Ends or Butt Weld Ends

Other End connections are available on request.

APPLICABLE STANDARDS

Design : ANSI B16.34
 End Flange : ANSI B16.5
 Weld Ends : ANSI B16.25
 Face-to-Face : ANSI B16.10
 Shell and Seat Test : API 598

MATERIAL

Option available for materials to meet NACE MR0175 requirement.

Dimensional Data (mm)*											
Size	Face -to-Face L	Dia. of Bore d	O.D. of Flange D	o of Bolt Circle C	O.D. of RF g	Thk of Flange t	Ht. of RF f	o of Bolt Holes h	Height H	Wall Thk a min	Wt (Kg)
2"	203.0	50.8	150.0	120.7	92.1	16.3	2.0	4-19.1	165	8.6	18.0
3"	241.0	76.2	190.0	152.4	127.0	19.5	2.0	4-19.1	186	10.4	29.0
4"	292.0	101.6	230.0	190.5	157.2	24.3	2.0	8-19.1	217	11.2	48.0
6"	356.0	152.4	280.0	241.3	215.9	25.9	2.0	8-22.4	266	11.9	77.0
8"	495.0	203.2	345.0	298.5	269.9	29.0	2.0	8-22.4	318	12.7	133.0
10"	622.0	254.0	405.0	362.0	323.8	30.6	2.0	12-25.4	368	14.2	266.0
12"	698.0	304.8	485.0	431.8	381.0	32.2	2.0	12-25.4	406	16.0	347.0
14"	787.0	336.6	535.0	476.3	412.8	35.4	2.0	12-28.6	432	16.8	451.0
16"	864.0	387.4	595.0	539.8	469.9	37.0	2.0	16-28.6	483	17.5	556.0
18"	978.0	438.2	635.0	577.9	533.4	40.1	2.0	16-32.0	600	18.3	784.0
20"	978.0	489.0	700.0	635.0	584.2	43.3	2.0	20-32.0	660	19.1	835.0
24"	1295.0	590.6	815.0	749.3	692.2	48.1	2.0	20-35.0	740	20.6	1150.0

* Please note dimensions are for information only. Order specific arrangement drawing dimensions will be final.

CAST STEEL SWING CHECK VALVE - ANSI 300

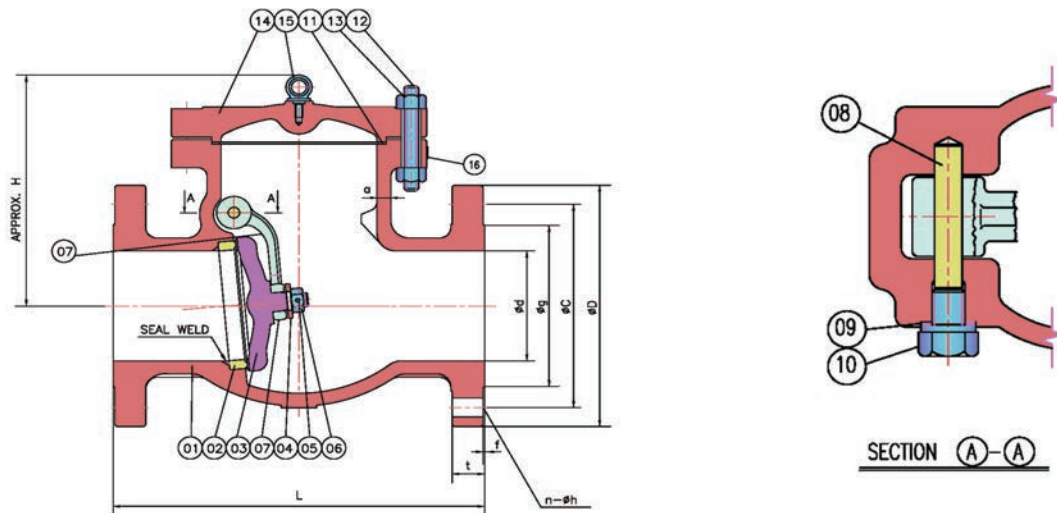

Parts And Material List **FIG . 0332F**

No.	Part Name	Material	ASTM Specification
01	Body	Carbon Steel	ASTM A216 Gr. WCB
02	Body Seat Ring	Carbon Steel	ASTM A105 ST'L No.6 Face
03	Disc	Carbon Steel	ASTM A216 13Cr Face
04	Washer	Carbon Steel	ASTM A276 316
05	Disc Nut Pin	Stainless Steel	ASTM A276 410
06	Disc Nut	Carbon Steel	ASTM A194 8
07	Arm	Carbon Steel	ASTM A216 WCB
08	Arm Pin	Stainless Steel	ASTM A276 410
09	Spring Washer	Stainless Steel	ASTM A276 316
10	Plug	Stainless Steel	ASTM A276 410
11	Gasket	Stainless Steel	Spiral Wound 316+Graphite
12	Cover Bolt	Carbon Steel	ASTM A193 B7
13	Cover Bolt Nut	Carbon Steel	ASTM A194 2H
14	Cover	Carbon Steel	ASTM A216 WCB
15	Eye Bolt	Carbon Steel	Carbon Steel
16	Nameplate	Stainless Steel	ASTM A182 F316

SPECIFICATION

- Bolted Cover
- For Horizontal or Vertical Lines (Up Flow Only)
- Welded or Threaded Seat Ring
- Raised Face Flanged Ends or Butt Weld Ends

Other End connections are available on request.

APPLICABLE STANDARDS

Design : ANSI B16.34
 End Flange : ANSI B16.5
 Weld Ends : ANSI B16.25
 Face-to-Face : ANSI B16.10
 Shell and Seat Test : API 598

MATERIAL

Option available for materials to meet NACE MR0175 requirement.

Dimensional Data (mm)*											
Size	Face -to-Face L	Dia. of Bore d	O.D. of Flange D	ø of Bolt Circle C	O.D. of RF g	Thk of Flange t	Ht. of RF f	ø of Bolt Holes n-h	Height H	Wall Thk a min	Wt (Kg)
2"	267.0	50.8	165.0	127.0	92.1	22.7	2.0	8-19.1	178	9.7	19.0
3"	318.0	76.2	210.0	168.3	127.0	29.0	2.0	8-22.4	211	11.9	29.0
4"	356.0	101.6	255.0	200.0	157.2	32.2	2.0	8-22.4	246	12.7	48.0
6"	444.0	152.4	320.0	269.9	215.9	37.0	2.0	12-22.4	318	16.0	77.0
8"	533.0	203.2	380.0	330.2	269.9	41.7	2.0	12-25.4	356	17.5	133.0
10"	622.0	254.0	445.0	387.4	323.8	48.1	2.0	16-28.6	394	19.1	266.0
12"	711.0	304.8	520.0	450.8	381.0	51.3	2.0	16-32.0	482	20.6	347.0
16"	864.0	387.4	650.0	571.5	469.9	57.6	2.0	20-35	584	23.9	840.0
18"	978.0	431.8	710.0	628.6	533.4	60.8	2.0	24-35	590	25.4	1025.0
20"	1016.0	482.6	775.0	685.8	584.2	64.0	2.0	24-35	614	26.9	1320.0
24"	1346.0	584.2	915.0	812.8	692.2	70.3	2.0	24-41	655	30.2	1960.0

* Please note dimensions are for information only. Order specific arrangement drawing dimensions will be final.

CAST STEEL SWING CHECK VALVE - ANSI 600

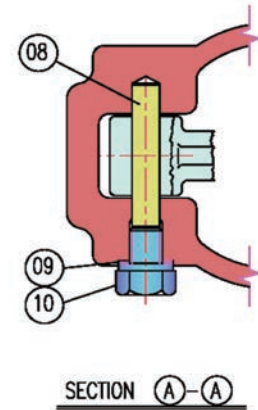
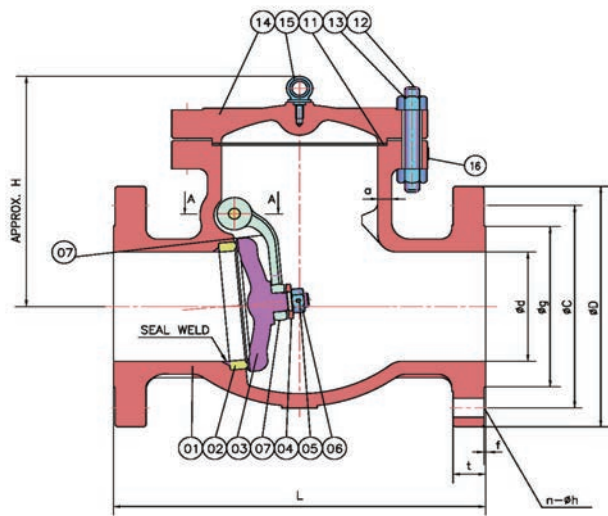

Parts And Material List			FIG . 0632F
No.	Part Name	Material	ASTM Specification
01	Body	Carbon Steel	ASTM A216 Gr. WCB
02	Body Seat Ring	Carbon Steel	ASTM A105 ST'L No.6 Face
03	Disc	Carbon Steel	ASTM A216 13Cr Face
04	Washer	Carbon Steel	ASTM A276 316
05	Disc Nut Pin	Stainless Steel	ASTM A276 410
06	Disc Nut	Carbon Steel	ASTM A194 8
07	Arm	Carbon Steel	ASTM A216 WCB
08	Arm Pin	Stainless Steel	ASTM A276 410
09	Spring Washer	Stainless Steel	ASTM A276 316
10	Plug	Stainless Steel	ASTM A276 410
11	Gasket	Stainless Steel	Spiral Wound 316+Graphite
12	Cover Bolt	Carbon Steel	ASTM A193 B7
13	Cover Bolt Nut	Carbon Steel	ASTM A194 2H
14	Cover	Carbon Steel	ASTM A216 WCB
15	Eye Bolt	Carbon Steel	Carbon Steel
16	Nameplate	Stainless Steel	ASTM A182 F316

SPECIFICATION

- Bolted Cover
- For Horizontal or Vertical Lines (Up Flow Only)
- Welded or Threaded Seat Ring
- Raised Face Flanged Ends or Butt Weld Ends

Other End connections are available on request.

APPLICABLE STANDARDS

Design : ANSI B16.34
 End Flange : ANSI B16.5
 Weld Ends : ANSI B16.25
 Face-to-Face : ANSI B16.10
 Shell and Seat Test : API 598

MATERIAL

Option available for materials to meet NACE MR0175 requirement.

Dimensional Data (mm)*											
Size	Face -to-Face L	Dia. of Bore d	O.D. of Flange D	o of Bolt Circle C	O.D. of RF g	Thk of Flange t	Ht. of RF f	o of Bolt Holes n-h	Height H	Wall Thk a min	Wt (Kg)
2"	292.0	50.8	165.0	127.0	92.1	25.4	7.0	8-19.1	187	11.2	52.0
3"	356.0	76.2	210.0	168.3	127.0	31.8	7.0	8-22.4	278	12.7	75.0
4"	432.0	101.6	275.0	215.9	157.2	38.1	7.0	8-25.4	316	16	122.0
6"	559.0	152.4	355.0	292.1	215.9	47.7	7.0	12-28.6	400	19.1	227.0
8"	660.0	199.9	420.0	349.2	269.9	55.6	7.0	12-32.0	432	25.4	346.0
10"	787.0	247.7	510.0	431.8	323.8	63.5	7.0	16-35.0	483	28.7	628.0
12"	838.0	298.5	560.0	489.0	381.0	66.7	7.0	20-35.0	508	31.8	796.0
14"	889.0	326.9	605.0	527.0	412.8	69.9	7.0	20-38.0	572	35.1	892.0
16"	991.0	374.7	685.0	603.2	469.9	76.2	7.0	20-41.0	660	38.1	1200.0
18"	1092.0	419.1	745.0	654.0	533.4	82.6	7.0	20-44.0	730	41.4	1600.0
20"	1094.0	463.6	815.0	723.9	584.2	88.9	7.0	24-44.0	800	44.5	2420.0
24"	1397.0	558.8	940.0	838.2	692.2	101.6	7.0	24-52.0	900	50.8	3150.0

* Please note dimensions are for information only. Order specific arrangement drawing dimensions will be final.

CAST STEEL SWING CHECK VALVE - ANSI 900

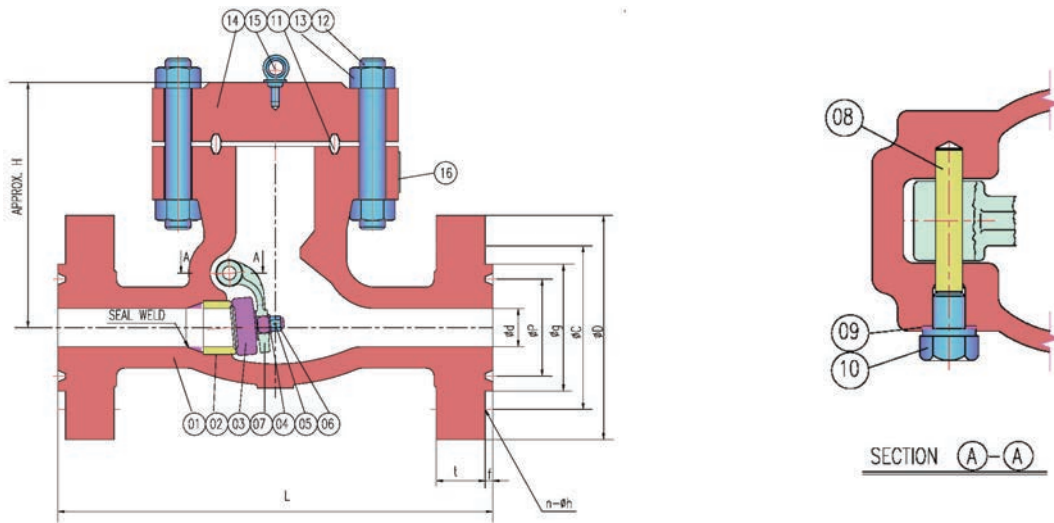

Parts And Material List **FIG . 0932R**

No.	Part Name	Material	ASTM Specification
01	Body	Carbon Steel	ASTM A216 Gr. WCB
02	Body Seat Ring	Carbon Steel	ASTM A105 ST'L No.6 Face
03	Disc	Carbon Steel	ASTM A216 13Cr Face
04	Washer	Carbon Steel	ASTM A276 316
05	Disc Nut Pin	Stainless Steel	ASTM A276 410
06	Disc Nut	Carbon Steel	ASTM A194 8
07	Arm	Carbon Steel	ASTM A216 WCB
08	Arm Pin	Stainless Steel	ASTM A276 410
09	Spring Washer	Stainless Steel	ASTM A276 316
10	Plug	Stainless Steel	ASTM A276 410
11	Gasket	Stainless Steel	316 SS Ring Joint
12	Cover Bolt	Carbon Steel	ASTM A193 B7
13	Cover Bolt Nut	Carbon Steel	ASTM A194 2H
14	Cover	Carbon Steel	ASTM A216 WCB
15	Eye Bolt	Carbon Steel	Carbon Steel
16	Nameplate	Stainless Steel	ASTM A182 F316

SPECIFICATION

- Bolted Cover
 - For Horizontal or Vertical Lines (Up Flow Only)
 - Welded or Threaded Seat Ring
 - Ring Type Joint or Butt Weld Ends
- Other End connections are available on request.

APPLICABLE STANDARDS

Design : ANSI B16.34
 End Flange : ANSI B16.5
 Weld Ends : ANSI B16.25
 Face-to-Face : ANSI B16.10
 Shell and Seat Test : API 598

MATERIAL

Option available for materials to meet NACE MR0175 requirement.

Dimensional Data (mm)*												
Size	Face -to-Face L	Dia. of Bore d	O.D. of Flange D	ø of Bolt Circle C	O.D. of RF g	ø of RTJ P	Thk of Flange t	Ht. of RF f	ø of Bolt Holes n-h	Height H	Wall Thk a min	Wt (Kg)
2"	371.3	47.5	215.0	165.1	124.0	95.25	38.1	7.9	8-25.4	225	19.1	69.0
3"	384.0	72.9	240.0	190.5	155.4	123.83	38.1	7.9	8-25.4	250	19.1	85.0
4"	460.2	98.3	290.0	235.0	180.8	149.23	44.5	7.9	8-32.0	320	21.3	145.0
6"	612.6	146.1	380.0	317.5	241.3	211.12	55.6	7.9	12-32.0	345	26.2	310.0
8"	739.6	190.5	470.0	393.7	307.8	269.88	63.5	7.9	12-38.0	415	31.8	500.0
10"	841.2	238.0	545.0	469.9	362.0	323.85	69.9	7.9	16-38.0	515	36.6	772.0
12"	968.2	282.4	610.0	533.4	419.1	381.00	79.4	7.9	20-38.0	560	42.2	1080.0

* Please note dimensions are for information only. Order specific arrangement drawing dimensions will be final.

CAST STEEL SWING CHECK VALVE - ANSI 1500

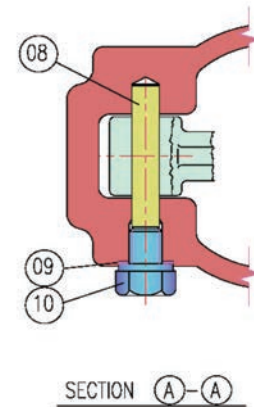
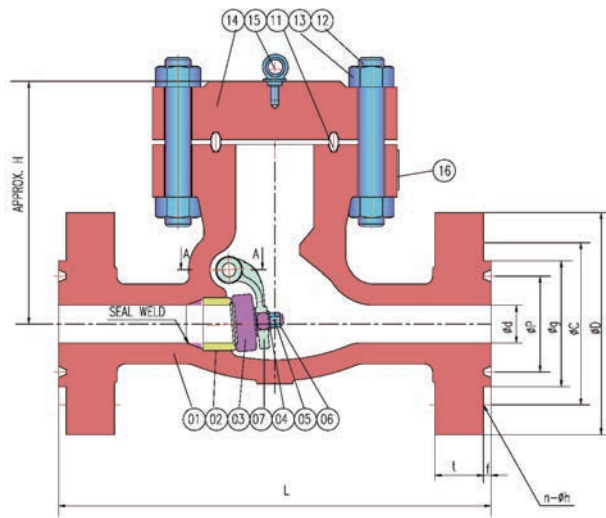

Parts And Material List			FIG . 1532R
No.	Part Name	Material	ASTM Specification
01	Body	Carbon Steel	ASTM A216 Gr. WCB
02	Body Seat Ring	Carbon Steel	ASTM A105 ST'L No.6 Face
03	Disc	Carbon Steel	ASTM A216 13Cr Face
04	Washer	Carbon Steel	ASTM A276 316
05	Disc Nut Pin	Stainless Steel	ASTM A276 410
06	Disc Nut	Carbon Steel	ASTM A194 8
07	Arm	Carbon Steel	ASTM A216 WCB
08	Arm Pin	Stainless Steel	ASTM A276 410
09	Spring Washer	Stainless Steel	ASTM A276 316
10	Plug	Stainless Steel	ASTM A276 410
11	Gasket	Stainless Steel	316 SS Ring Joint
12	Cover Bolt	Carbon Steel	ASTM A193 B7
13	Cover Bolt Nut	Carbon Steel	ASTM A194 2H
14	Cover	Carbon Steel	ASTM A216 WCB
15	Eye Bolt	Carbon Steel	Carbon Steel
16	Nameplate	Stainless Steel	ASTM A182 F316

SPECIFICATION

- Bolted Cover
 - For Horizontal or Vertical Lines (Up Flow Only)
 - Welded or Threaded Seat Ring
 - Ring Type Joint or Butt Weld Ends
- Other End connections are available on request.

APPLICABLE STANDARDS

Design : ANSI B16.34
 End Flange : ANSI B16.5
 Weld Ends : ANSI B16.25
 Face-to-Face : ANSI B16.10
 Shell and Seat Test : API 598

MATERIAL

Option available for materials to meet NACE MR0175 requirement.

Dimensional Data (mm)*												
Size	Face -to-Face L	Dia. of Bore d	O.D. of Flange D	ø of Bolt Circle C	O.D. of RF g	ø of RTJ P	Thk of Flange t	Ht. of RF f	ø of Bolt Holes n-h	Height H	Wall Thk a min	Wt (Kg)
2"	371.3	47.5	215.0	165.1	124.0	95.25	38.1	7.9	8-25.4	225	19.1	60.0
3"	472.9	69.9	265.0	203.2	168.1	136.53	47.7	7.9	8-32.0	330	23.9	78.0
4"	549.1	91.9	310.0	241.3	193.5	161.93	54.0	7.9	8-35.0	355	28.7	130.0
6"	711.2	136.4	395.0	317.5	247.7	211.12	82.6	9.5	12-38.0	450	38.1	334.0
8"	841.5	177.8	485.0	393.7	317.5	269.88	92.1	11.1	12-44.0	460	47.8	590.0
10"	1000.3	222.3	585.0	482.6	371.3	323.85	108.0	11.1	12-52.0	519	57.2	1025.0

* Please note dimensions are for information only. Order specific arrangement drawing dimensions will be final.

CAST STEEL SWING CHECK VALVE - ANSI 1500 PRESSURE SEAL BONNET

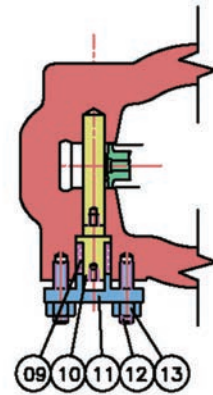
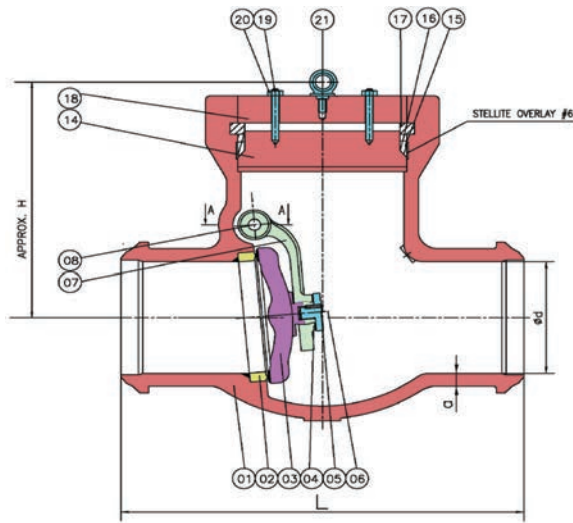

Parts And Material List			FIG . 1572B
No.	Part Name	Material	ASTM Specification
01	Body	Carbon Steel	ASTM A216 Gr. WCB
02	Body Seat Ring	Carbon Steel	ASTM A105 ST'L No.6 Face
03	Disc	Carbon Steel	ASTM A105 ST'L No.6 Face
04	Washer	Stainless Steel	ASTM A276 316
05	Disc Nut Screw	Stainless Steel	ASTM A276 410
06	Disc Nut	Carbon Steel	ASTM A194 8
07	Hinge	Carbon Steel	ASTM A216 WCB
08	Pin	Stainless Steel	ASTM A276 410
09	Packing	Graphite	Graphite
10	Hinge pin	Stainless Steel	ASTM A276 410
11	Plug	Stainless Steel	ASTM A276 410
12	Plug Bolt	Carbon Steel	ASTM A193 B7
13	Plug bolt Nut	Carbon Steel	ASTM A194 2H
14	Cover	Carbon Steel	ASTM A105
15	Sealing Ring	Stainless Steel	ASTM A276 316L
16	Pressure Ring	Stainless Steel	ASTM A276 410
17	Segment Ring	Stainless Steel	ASTM A276 410
18	Cover Clamp	Carbon Steel	ASTM A105
19	Cover Bolt	Carbon Steel	ASTM A193 B7
20	Cover Bolt Nut	Carbon Steel	ASTM A194 2H
21	Eye Bolt	Carbon Steel	Carbon Steel

SPECIFICATION

- Bolted Cover
 - For Horizontal or Vertical Lines (Up Flow Only)
 - Welded or Threaded Seat Ring
 - Butt Weld Ends
- Other End connections are available on request.

APPLICABLE STANDARDS

Design : ANSI B16.34
 End Flange : ANSI B16.5
 Weld Ends : ANSI B16.25
 Face-to-Face : ANSI B16.10
 Shell and Seat Test : API 598

MATERIAL

Option available for materials to meet NACE MR0175 requirement.

Dimensional Data (mm)*					
Size	Face-to-Face L	Dia. of Bore d	Height H	Wall Thk a min	Wt (Kg)
3"	305.0	69.9	330.0	23.9	78.0
4"	406.0	91.9	355.0	28.7	130.0
6"	559.0	136.4	400.0	38.1	334.0
8"	711.0	177.8	460.0	47.8	590.0
10"	864.0	222.3	630.0	57.2	1025.0

* Please note dimensions are for information only. Order specific arrangement drawing dimensions will be final.

FIGURE NUMBERING SYSTEM

Example : -

Fig.	01 ANSI Rating	1 Valve Type	2 Body / Bonnet Material	F End Connection	8 Seating Trim
-------------	--------------------------	------------------------	------------------------------------	----------------------------	--------------------------

ANSI Rating	Valve Type	Body / Bonnet Material	End Connection
01 = ANSI 150	1 = Gate	1 = Low Carbon Steel - ASTM A352 LCB / LC3 / LCC	B = Bevel Weld
03 = ANSI 300	2 = Globe	2 = Carbon Steel - ASTM A216 Gr.WCB	F = Raised Face Flange
06 = ANSI 600	3 = Swing Check	3 = Stainless Steel - ASTM A351 CF8M / CF3M	R = Ring Type Joint
09 = ANSI 900	5 = PS Gate	4 = Stainless Steel - ASTM A351 CF8 / CF3 / CF10	
15 = ANSI 1500	6 = PS Globe	5 = Stainless Steel - ASTM A351 CF8C (Type 347)	
25 = ANSI 2500*	7 = PS Check	6 = Stainless Steel - ASTM A351 CG8M / CG3M	
	0 = Others	7 = Alloy Steel - ASTM A217 WC1 / WC6 / WC9 / C5 / C12	
		8 = Alloy 20 - ASTM A351CN7M	
		9 = Duplex Stainless Steel	
		0 = Hastelloy, Monel or Others	

* Available on request
PS denotes Pressure Seal

** With Reference from API 600

Seating Trim						
Trim No	Trim	Seat Surface Hardness (Hb ^a Min.)	Body Seating Surface(Facing)	Gate / Disc Seating Surface(Facing)	Backseat*	Stem*
1	F6	^b	13Cr	13Cr	13Cr(410)	13Cr(410)
2	304	^c	18 Cr-8Ni(304)	SS304	SS304	SS304
5	Hardfaced	350 ^d	Stellite 6	Stellite 6	13Cr	13Cr(410)
8	F6 and HF	250 ^e & 350 ^f	Stellite 6	13Cr	13Cr(410)	13Cr(410)
9	Monel	^c	Ni-Cu alloy	Ni-Cu alloy	Ni-Cu alloy	Ni-Cu alloy
10	316	^c	18Cr-8Ni	SS316	SS316	SS316
11	Monel & HF	^c & 350 ^f	Stellite 6	Ni-Cu alloy	Ni-Cu alloy	Ni-Cu alloy
12	316 & HF	^c & 350 ^f	Stellite 6	SS316	SS316	SS316
13	Alloy 20	^c	19Cr-29Ni	19Cr-29Ni	19Cr-29Ni	19Cr-29Ni
14	Alloy 20 & HF	^c & 350 ^f	Stellite 6	19Cr-29Ni	19Cr-29Ni	19Cr-29Ni
15	Hardfaced	350 ^d	Stellite 6	Stellite 6	SS304	SS304
16	Hardfaced	350 ^d	Stellite 6	Stellite 6	SS316	SS316
ST	Special Trim	NA	Others	Others	Others	Others

Note:

- * Backseat and Stem only applies to Gate and Globe Valves.
For Swing Check Valve, Trim material includes Hinge Pin material which will take reference from stem material.
- ^a HB (formerly HBN) is the symbol for Brinell Hardness per ASTM E10.
- ^b Body and gate seat 250HB minimum, with 50 HB minimum differential between body and gate seat surfaces.
- ^c Manufacturer's standard hardness.
- ^d Differential hardness between the body and gate seat surfaces is not required.
- ^f Hardness differential between body and gate seat surfaces shall be manufacturer's standard.

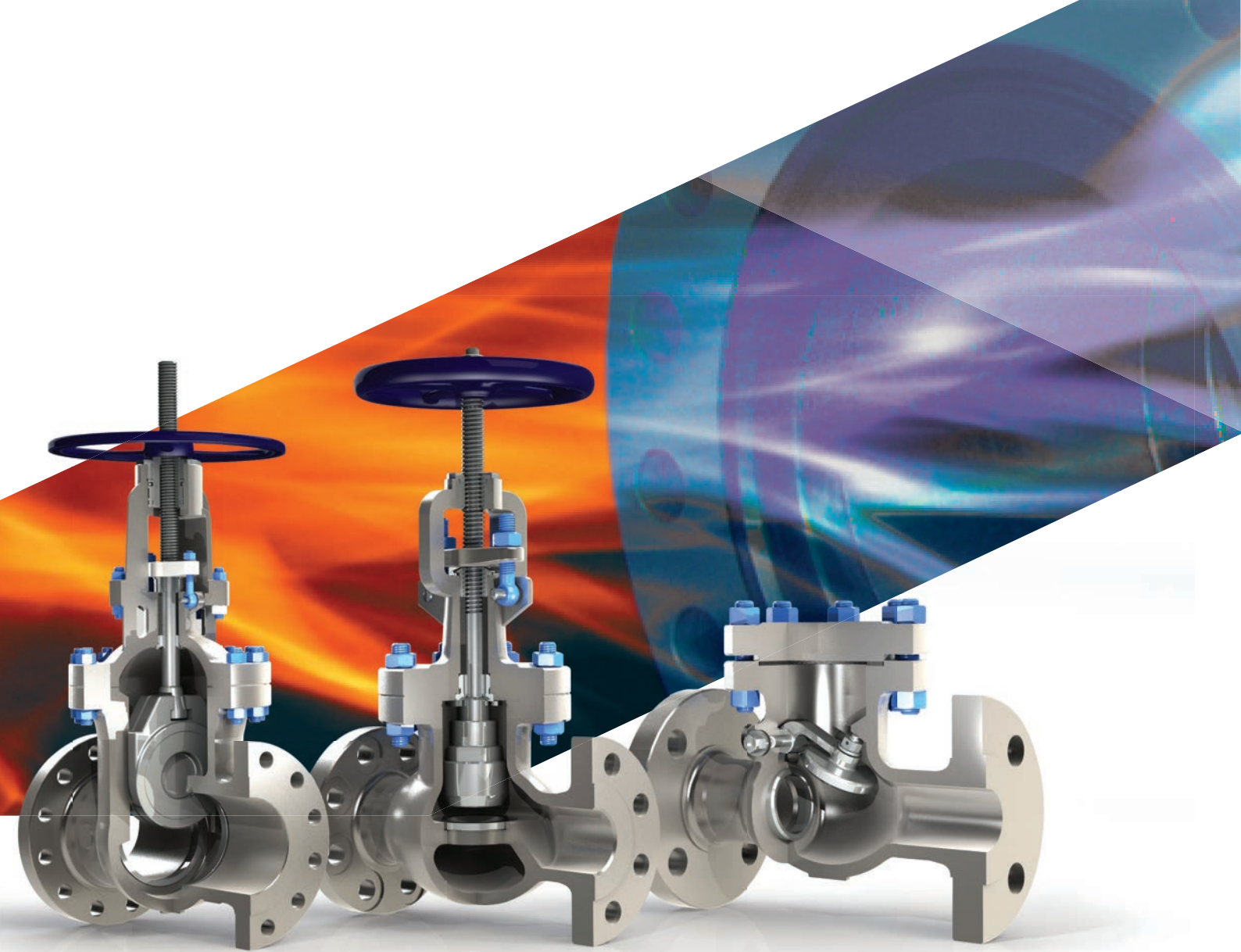

ENGINEERING DATA

ENGINEERING DATA

MATERIALS

Cross Reference of ASTM Material Designation Between Cast and Equivalent Forge

Important Note: Data provided on this chart is for information purposes only. Always refer to current ASTM standards to verify information and cross reference data.

CHEMICAL COMPOSITION	ASTM CAST	ASTM FORGED
CARBON STEEL		
0.25/0.35% C Max	A216 WCB	A105
LOW TEMPERATURE STEEL		
0.25/0.30% C Max	A352 LCB	A350 LF2
0.5 Ni	A352 LCC	
0.5 Mo	A352 LC1	
2 Ni	A352 LC2	
3.5 Ni	A352 LC3	A350 LF3
ALLOY STEEL		
0.5 Mo	A217 WC 1	A182 F1
1.25 Cr - 0.5 Mo	A217 WC 6	A182 F11
2.25 Cr - 1 Mo	A217 WC 9	A182 F22
5 Cr - 0.5 Mo	A217 C5	A182 F5
9 Cr - 1 Mo	A217 C12	A182 F9
STAINLESS STEEL		
13 Cr	A217 CA15	A182 F6
19 Cr - 9 Ni	A351 CF8	A182 F304
19 Cr - 10 Ni Low Carbon	A351 CF3	A182 F304L
19 Cr - 10 Ni - 2 Mo	A351 CF8M	A182 F316
19 Cr - 10 Ni - 2 Mo Low Carbon	A351 CF3M	A182 F316L
19 Cr - 9 Ni - Cb	A351 CF8C	A182 F347
DUPLEX STEEL		
19-22 Cr 27.5-30.5 Ni 2-3 Mo	A351 CN7M	B473
24-25 Cr 7-10 Ni 4 Mo N/V	A351 CD4MCU	A182 F53
18-21 Cr 9-13 Ni 3-4 Mo	A351 CG8M	
21-23.5 Cr 4.5-6.5 Ni 2.5-3.5 Mo	A890 4A / A351 CD3MN	A182 F51
24-26 Cr 6.5-8.5 Ni 3-4 Mo	A995 CD3MWCuN	A182 F55

PRESSURE TEMPERATURE

PRESSURE TEMPERATURE RATING FOR ASTM A216 WCB

SERVICE TEMPERATURE		CLASS 150	CLASS 300	CLASS 600	CLASS 900	CLASS 1500	CLASS 2500
°F	°C	psi	psi	psi	psi	psi	psi
-20 to 100	-29 to 38	285	740	1480	2220	3705	6170
200	93	260	680	1360	2035	3395	5655
300	149	230	655	1310	1965	3270	5450
400	204	200	635	1265	1900	3170	5280
500	260	170	605	1205	1810	3015	5025
600	316	140	570	1135	1705	2840	4730
650	343	125	550	1100	1650	2745	4575
700	371	110	530	1060	1590	2665	4425
750	399	95	505	1015	1520	2535	4230
800	427	80	410	825	1235	2055	3430
850	454	65	320	640	955	1595	2655
900	482	50	230	460	690	1150	1915
950	510	35	135	275	410	685	1145
1000	538	20	85	170	255	430	715

Note: A216 WCB, permissible, but not recommended for prolonged use above 800°F

PRESSURE TEMPERATURE RATING FOR ASTM A351 CF8M

SERVICE TEMPERATURE		CLASS 150	CLASS 300	CLASS 600	CLASS 900	CLASS 1500	CLASS 2500
°F	°C	psi	psi	psi	psi	psi	psi
-20 to 100	-29 to 38	275	720	1440	2160	3600	6000
200	93	235	620	1240	1860	3095	5160
300	149	215	560	1120	1680	2795	4660
400	204	195	515	1025	1540	2570	4280
500	260	170	480	955	1435	2390	3980
600	316	140	450	900	1355	2255	3760
650	343	125	440	885	1325	2210	3680
700	371	110	435	870	1305	2170	3620
750	399	95	425	855	1280	2135	3560
800	427	80	420	845	1265	2110	3520
850	454	65	420	835	1255	2090	3480
900	482	50	415	830	1245	2075	3460
950	510	35	385	775	1160	1930	3220
1000	538	20	365	725	1090	1820	3030

PRESSURE TEMPERATURE RATING FOR ASTM A352 LCB

SERVICE TEMPERATURE		CLASS 150	CLASS 300	CLASS 600	CLASS 900	CLASS 1500	CLASS 2500
°F	°C	psi	psi	psi	psi	psi	psi
-20 to 100	-29 to 38	265	695	1395	2090	3480	5805
200	93	255	660	1320	1980	3300	5505
300	149	230	640	1275	1915	3190	5315
400	204	200	615	1230	1845	3075	5125
500	260	170	585	1175	1760	2930	4885
600	316	140	550	1105	1655	2755	4595
650	343	125	535	1065	1600	2665	4440
700	371	110	510	1025	1535	2560	4270
750	399	95	475	955	1430	2385	3970
800	427	80	390	780	1175	1955	3255
850	454	65	300	595	895	1490	2485
900	482	50	200	405	605	1010	1685
950	510	35	135	275	410	685	1145
1000	538	20	85	170	255	430	715

Note: A352 LCB not to be used over 650°F

B16.5 DIMENSIONS RF

DIMENSIONS FOR CLASS 150 & 300 RAISED FACE

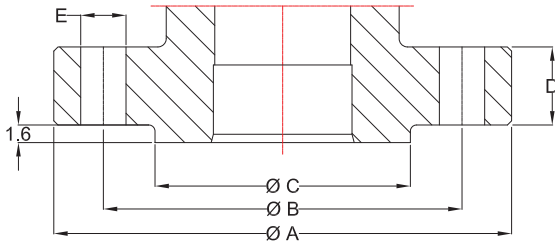

DIMENSIONS FOR CLASS 600 & HIGHER RAISED FACE

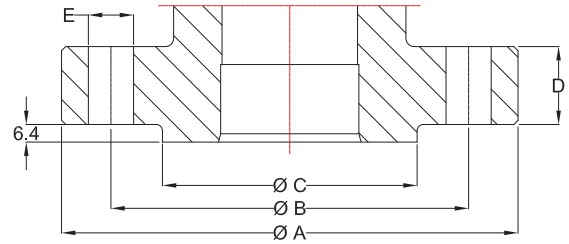

CLASS 150 STEEL PIPE FLANGE DIMENSIONS

NOMINAL SIZE		A		B		C		D		E		BOLT	
in	mm	in	mm	in	mm	in	mm	in	mm	in	mm	No.	Dia. "
2	50	6.00	150.0	4.75	120.7	3.62	92.0	0.69	17.5	0.75	19.0	4	5/8
2½	65	7.00	180.0	5.50	139.7	4.12	105.0	0.81	20.7	0.75	19.0	4	5/8
3	80	7.50	190.0	6.00	152.4	5.00	127.0	0.88	22.3	0.75	19.0	4	5/8
4	100	9.00	230.0	7.50	190.5	6.19	157.0	0.88	22.3	0.75	19.0	8	5/8
6	150	11.00	280.0	9.50	241.3	8.50	216.0	0.94	23.9	0.88	22.0	8	3/4
8	200	13.60	345.0	11.75	298.5	10.62	270.0	1.06	27.0	0.88	22.0	8	3/4
10	250	16.00	405.0	14.25	362.0	12.75	324.0	1.13	28.6	1.00	25.0	12	7/8
12	300	19.10	485.0	17.00	431.8	15.00	381.0	1.19	30.2	1.00	25.0	12	7/8
14	350	21.10	535.0	18.75	476.3	16.25	413.0	1.31	33.4	1.12	29.0	12	1
16	400	23.40	595.0	21.25	539.8	18.50	470.0	1.38	35.0	1.12	29.0	16	1
18	450	25.00	635.0	22.75	577.9	21.00	533.0	1.50	38.1	1.25	32.0	16	1.1/8
20	500	27.60	700.0	25.00	635.0	23.00	584.0	1.63	41.3	1.25	32.0	20	1.1/8
24	600	32.10	815.0	29.50	749.3	27.25	692.0	1.81	46.1	1.38	35.0	20	1.1/4

CLASS 300 STEEL PIPE FLANGE DIMENSIONS

NOMINAL SIZE		A		B		C		D		E		BOLT	
in	mm	in	mm	in	mm	in	mm	in	mm	in	mm	No.	Dia. "
2	50	6.50	165.0	5.00	127.0	3.62	92.0	0.88	20.7	0.75	19.0	8	5/8
2½	65	7.50	190.0	5.88	149.0	4.12	105.0	1.00	23.9	0.88	22.0	8	3/4
3	80	8.27	210.0	6.61	168.0	5.00	127.0	1.12	27.0	0.88	22.0	8	3/4
4	100	10.00	255.0	7.87	200.0	6.19	157.0	1.25	30.2	0.88	22.0	8	3/4
6	150	12.60	320.0	10.62	270.0	8.50	216.0	1.44	35.0	0.88	22.0	12	3/4
8	200	15.00	380.0	13.00	330.0	10.62	270.0	1.62	39.7	1.00	25.0	12	7/8
10	250	17.50	445.0	15.25	387.5	12.75	324.0	1.88	46.1	1.12	29.0	16	1
12	300	20.50	520.0	17.75	451.0	15.00	381.0	2.00	49.3	1.25	32.0	16	1.1/8
14	350	23.00	585.0	20.25	514.5	16.25	413.0	2.12	52.4	1.25	32.0	20	1.1/8
16	400	25.60	650.0	22.50	571.5	18.50	470.0	2.25	55.6	1.38	35.0	20	1.1/4
18	450	28.00	711.0	24.75	628.5	21.00	533.0	2.38	58.8	1.38	35.0	24	1.1/4
20	500	30.50	775.0	27.00	686.0	23.00	584.0	2.50	62.0	1.38	35.0	24	1.1/4
24	600	36.00	915.0	32.00	813.0	27.25	692.0	2.75	68.3	1.62	41.0	24	1.1/2

CLASS 600 STEEL PIPE FLANGE DIMENSIONS

NOMINAL SIZE		A		B		C		D		E		BOLT	
in	mm	in	mm	in	mm	in	mm	in	mm	in	mm	No.	Dia. "
2	50	6.50	165.0	5.00	127.0	3.62	92.0	1.00	25.4	0.75	19.0	8	5/8
2½	65	7.50	190.0	5.88	149.2	4.12	105.0	1.12	28.6	0.88	22.0	8	3/4
3	80	8.27	210.0	6.62	168.3	5.00	127.0	1.25	31.8	0.88	22.0	8	3/4
4	100	10.80	275.0	8.50	215.9	6.19	157.0	1.50	38.1	1.00	25.0	8	7/8
6	150	14.00	355.0	11.50	292.1	8.50	216.0	1.88	47.7	1.12	29.0	12	1
8	200	16.50	420.0	13.75	349.2	10.62	270.0	2.19	55.6	1.25	32.0	12	1.1/8
10	250	20.00	510.0	17.00	431.8	12.75	324.0	2.50	63.5	1.38	35.0	16	1.1/4
12	300	22.00	560.0	19.25	489.0	15.00	381.0	2.62	66.7	1.38	35.0	20	1.1/4
14	350	23.80	605.0	20.75	527.0	16.25	413.0	2.75	69.9	1.50	38.0	20	1.3/8
16	400	27.00	685.0	23.75	603.2	18.50	470.0	3.00	76.2	1.62	41.0	20	1.1/2
18	450	29.30	745.0	25.75	654.0	21.00	533.0	3.25	82.6	1.75	45.0	20	1.5/8
20	500	32.00	815.0	28.50	723.9	23.00	584.0	3.50	88.9	1.75	45.0	24	1.5/8
24	600	37.00	940.0	33.00	838.2	27.25	692.0	4.00	102	2.00	51.0	24	1.7/8

B16.5 DIMENSIONS RF

DIMENSIONS FOR CLASS 600 & HIGHER RAISED FACE

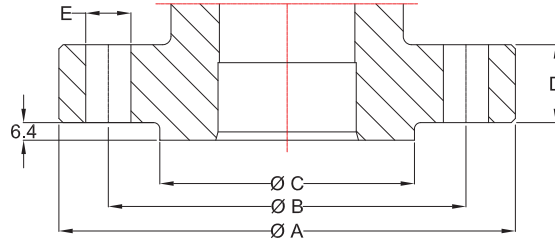

CLASS 900 STEEL PIPE FLANGE DIMENSIONS

NOMINAL SIZE		A		B		C		D		E		BOLT	
in	mm	in	mm	in	mm	in	mm	in	mm	in	mm	No.	Dia."
2	50	8.50	215.0	6.50	165.1	3.62	92.0	1.50	38.1	1.00	25.0	8	7/8
2½	65	9.62	245.0	7.50	190.5	4.12	105.0	1.62	41.3	1.12	29.0	8	1
3	80	9.50	240.0	7.50	190.5	5.00	127.0	1.50	38.1	1.00	25.0	8	7/8
4	100	11.50	290.0	9.25	235.0	6.19	157.0	1.75	44.5	1.25	32.0	8	1.1/8
6	150	15.00	380.0	12.50	317.5	8.50	216.0	2.19	55.6	1.25	32.0	12	1.1/8
8	200	18.50	470.0	15.50	393.5	1.62	270.0	2.50	63.5	1.50	38.0	12	1.3/8
10	250	21.50	545.0	18.50	469.9	12.75	324.0	2.75	69.9	1.50	38.0	16	1.3/8
12	300	24.00	610.0	21.00	533.4	15.00	381.0	3.12	79.4	1.50	38.0	20	1.3/8
14	350	25.25	640.0	22.00	558.8	16.25	413.0	3.38	85.8	1.62	41.0	20	1.1/2
16	400	27.75	705.0	24.25	616.0	18.50	470.0	3.50	88.9	1.75	45.0	20	1.5/8
18	450	31.00	785.0	27.00	685.8	21.00	533.0	4.00	101.6	2.00	51.0	20	1.7/8
20	500	33.75	855.0	29.50	749.3	23.00	584.0	4.25	108.0	2.12	54.0	20	2
24	600	41.00	1040.0	35.50	901.7	27.25	692.0	5.50	139.7	2.62	67.0	20	2.1/2

CLASS 1500 STEEL PIPE FLANGE DIMENSIONS

NOMINAL SIZE		A		B		C		D		E		BOLT	
in	mm	in	mm	in	mm	in	mm	in	mm	in	mm	No.	Dia."
2	50	8.50	215.0	6.50	165.0	3.62	92.0	1.50	38.1	1.00	25.0	8	7/8
2½	65	9.70	245.0	7.50	190.5	4.12	105.0	1.63	41.3	1.12	29.0	8	1
3	80	10.40	265.0	8.00	203.0	5.00	127.0	1.88	47.7	1.25	32.0	8	1.1/8
4	100	12.20	310.0	9.50	241.5	6.19	157.0	2.13	54.0	1.38	35.0	8	1.1/4
6	150	15.60	395.0	12.50	317.5	8.50	216.0	3.25	82.6	1.50	38.0	12	1.3/8
8	200	19.10	485.0	15.50	393.7	10.62	270.0	3.63	92.1	1.75	45.0	12	1.5/8
10	250	23.00	585.0	19.00	482.6	12.75	324.0	4.25	108.0	2.00	51.0	12	1.7/8
12	300	26.60	675.0	22.50	571.5	15.00	381.0	4.88	123.9	2.12	54.0	16	2
14	350	29.50	750.0	25.00	635.0	16.25	413.0	5.25	133.4	2.38	60.0	16	2.1/4
16	400	32.50	825.0	27.75	704.8	18.50	470.0	5.75	146.1	2.62	67.0	16	2.1/2
18	450	36.00	915.0	30.50	774.7	21.00	533.0	6.38	162.0	2.88	73.0	16	2.3/4
20	500	38.80	985.0	32.75	831.8	23.00	584.0	7.00	177.8	3.12	79.0	16	3
24	600	46.00	1170.0	39.00	990.6	27.25	692.0	8.00	203.2	3.62	92.0	16	3.1/2

CLASS 2500 STEEL PIPE FLANGE DIMENSIONS

NOMINAL SIZE		A		B		C		D		E		BOLT	
in	mm	in	mm	in	mm	in	mm	in	mm	in	mm	No.	Dia."
2	50	9.25	235.0	6.75	171.4	3.62	92.0	2.00	50.9	1.12	29.0	8	1
2½	65	10.40	265.0	7.75	196.8	4.12	105.0	2.25	57.2	1.25	32.0	8	1.1/8
3	80	12.00	305.0	9.00	228.6	5.00	127.0	2.62	66.7	1.38	35.0	8	1.1/4
4	100	14.00	355.0	10.75	273.0	6.19	157.0	3.00	76.2	1.62	41.0	8	1.1/2
6	150	19.00	485.0	14.50	323.8	8.50	216.0	4.25	108.0	2.12	54.0	8	2
8	200	21.65	550.0	17.25	438.2	10.62	270.0	5.00	127.0	2.12	54.0	12	2
10	250	26.60	675.0	21.25	539.8	12.75	324.0	6.50	165.1	2.62	67.0	12	2.1/2
12	300	30.00	760.0	24.38	619.1	15.00	381.0	7.25	184.2	2.88	73.0	12	2.3/4

B16.5 DIMENSIONS RTJ

DIMENSIONS FOR CLASS 900, 1500 & 2500 RING TYPE JOINT

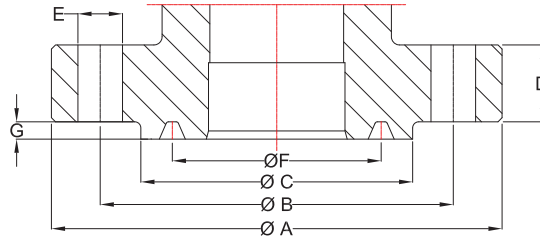

CLASS 900 STEEL PIPE FLANGE DIMENSIONS

NOMINAL SIZE		A		B		C		D		E		F		G		BOLT		RTJ Ring #
in	mm	in	mm	in	mm	in	mm	in	mm	in	mm	in	mm	in	mm	No.	Dia."	
2	50	8.50	215.0	6.50	165.1	4.88	124.0	1.50	38.1	1.00	25.0	3.75	95.25	0.31	7.92	8	7/8	24
2½	65	9.62	245.0	7.50	190.5	5.39	137.0	1.62	41.3	1.12	29.0	4.25	107.95	0.31	7.92	8	1	27
3	80	9.50	240.0	7.50	190.5	6.14	156.0	1.50	38.1	1.00	25.0	4.88	123.83	0.31	7.92	8	7/8	31
4	100	11.50	290.0	9.25	235.0	7.12	181.0	1.75	44.5	1.25	32.0	5.88	149.23	0.31	7.92	8	1.1/8	37
6	150	15.00	380.0	12.50	317.5	9.49	241.0	2.19	55.6	1.25	32.0	8.31	211.12	0.31	7.92	12	1.1/8	45
8	200	18.50	470.0	15.50	393.5	12.13	308.0	2.50	63.5	1.50	38.0	10.63	269.88	0.31	7.92	12	1.3/8	49
10	250	21.50	545.0	18.50	469.9	14.25	362.0	2.75	69.9	1.50	38.0	12.75	323.85	0.31	7.92	16	1.3/8	53
12	300	24.00	610.0	21.00	533.4	16.50	419.0	3.12	79.4	1.50	38.0	15.00	381.00	0.31	7.92	20	1.3/8	57

CLASS 1500 STEEL PIPE FLANGE DIMENSIONS

NOMINAL SIZE		A		B		C		D		E		F		G		BOLT		RTJ Ring #
in	mm	in	mm	in	mm	in	mm	in	mm	in	mm	in	mm	in	mm	No.	Dia."	
2	50	8.50	215.0	6.50	165.0	4.88	124.0	1.50	38.1	1.00	25.0	3.75	95.25	0.31	7.92	8	7/8	24
2½	65	9.70	245.0	7.50	190.5	5.39	137.0	1.63	41.3	1.12	29.0	4.25	107.95	0.31	7.92	8	1	27
3	80	10.40	265.0	8.00	203.0	6.61	168.0	1.88	47.7	1.25	32.0	5.38	136.53	0.31	7.92	8	1.1/8	35
4	100	12.20	310.0	9.50	241.5	7.64	194.0	2.13	54.0	1.38	35.0	6.38	161.93	0.31	7.92	8	1.1/4	39
6	150	15.60	395.0	12.50	317.5	9.76	248.0	3.25	82.6	1.50	38.0	8.31	211.14	0.38	9.53	12	1.3/8	46
8	200	19.10	485.0	15.50	393.7	12.52	318.0	3.63	92.1	1.75	45.0	10.63	269.88	0.44	11.13	12	1.5/8	50
10	250	23.00	585.0	19.00	482.6	14.60	371.0	4.25	108.0	2.00	51.0	12.75	323.85	0.44	11.13	12	1.7/8	54
12	300	26.60	675.0	22.50	571.5	17.24	438.0	4.88	123.9	2.12	54.0	15.00	381.00	0.56	14.27	16	2	58

CLASS 2500 STEEL PIPE FLANGE DIMENSIONS

NOMINAL SIZE		A		B		C		D		E		F		G		BOLT		RTJ Ring #
in	mm	in	mm	in	mm	in	mm	in	mm	in	mm	in	mm	in	mm	No.	Dia."	
2	50	9.25	235.0	6.75	171.4	5.24	133.0	2.00	50.9	1.12	29.0	4.00	101.60	0.31	7.92	8	1	26
2½	65	10.40	265.0	7.75	196.8	5.87	149.0	2.25	57.2	1.25	32.0	4.38	111.13	0.38	9.53	8	1.1/8	28
3	80	12.00	305.0	9.00	228.6	6.61	168.0	2.62	66.7	1.38	35.0	5.00	127.00	0.38	9.53	8	1.1/4	32
4	100	14.00	355.0	10.75	273.0	7.99	203.0	3.00	76.2	1.62	41.0	6.19	157.18	0.44	11.13	8	1.1/2	38
6	150	19.00	485.0	14.50	323.8	10.98	279.0	4.25	108.0	2.12	54.0	9.00	228.60	0.50	12.70	8	2	47
8	200	21.65	550.0	17.25	438.2	13.39	340.0	5.00	127.0	2.12	54.0	11.00	279.40	0.56	14.27	12	2	51
10	250	26.60	675.0	21.25	539.8	16.73	425.0	6.50	165.1	2.62	67.0	13.50	342.90	0.69	17.48	12	2.1/2	55
12	300	30.00	760.0	24.38	619.1	19.49	495.0	7.25	184.2	2.88	73.0	16.00	406.40	0.69	17.48	12	2.3/4	60



6 Beardmore Way, Clydebank Industrial Estate,
Clydebank , G81 4HT,
Scotland, UK

Tel: (44) 141 435 7640

Fax: (44) 141 435 7647

Website: www.kvc-uk.com

Email: sales@kvc-uk.com

Exclusive Agent / Distributor / Stockist (Asia Pacific)

Federal Hardware Engineering Co. Pte Ltd

47/49 Genting Road

Singapore 349489

Tel: (65) 67478118

Fax: (65) 6743 0690/ 6745 0048

Website: www.federal.com.sg

Email: sales@fedsin.com.sg